



EN

Installation, Operation and Maintenance

VENTUS Air-Handling Units

Rated CFM from 800 to 38200



VENTUS

OMM-AVS-ver.6.2 (12.2019)

Table of content

1	Warnings, Cautions and Notices	4
2	Model Descriptions	4
3	General Information	7
4	Pre-Installation	8
4.1	Receiving and Handling	8
4.1.1	Shipping Package	9
4.1.2	Ship-Separate Accessories	9
4.1.3	Receiving Checklist.....	9
4.1.4	Jobsite Storage Recommendation	10
4.2	Installation Preparation.....	10
4.2.1	Service Access.....	11
4.2.2	Rigging and Handling	11
4.2.3	Unit Location Recommendations.....	12
4.2.4	Skid Removal	13
4.3	Pre-Installation Checklist	13
5	Dimensions and Weights.....	14
5.1	Horizontal AHU	14
5.2	Horizontal AHU with Heat Wheel and Cross-Flow Exchanger.....	16
5.3	Vertical AHU.....	17
5.4	AHU components connection.....	17
5.4.1	Hydronic coil exchangers.....	17
5.4.2	DX Coils.....	20
5.4.3	Electric Heaters	22
5.4.4	Air Filters	22
6	Installation of Variable Frequency Drive (Frequency Converter)	23
7	Installation: Electrical	24
7.1	Unit Wiring Diagrams	24
7.2	Power Supply Wiring	24
7.3	Electrical Connections.....	25
7.4	Electrical Grounding Restrictions	25
7.5	Full Load Amps and Maximum Circuit Breaker.....	26
7.5.1	Electric Heater.....	26
7.5.2	Electric motor with frequency converter.....	36
7.6	Frequency Converter Wiring	38
8	Installation: Mechanical	43

8.1	Installing the Unit	45
8.2	Condensate Drain Connections	50
8.3	Duct Connections	51
9	Installation: Piping	51
9.1	Hydronic Coil Connections	51
9.2	Steam Piping.....	53
9.3	Refrigerant Coil Piping.....	55
10	Pre-Start.....	57
11	Maintenance	58
11.1	Maintenance Procedures.	58
11.2	Coil Maintenance	59
11.3	Periodic Maintenance Checklists.....	60

In-depth familiarization with the content of this manual, assembly, start-up and operation of the air handling unit in line with the instructions provided and following all safety regulations will ensure the basis of efficient, safe and non-failure operation of the device.

1 Warnings, Cautions and Notices

SAFETY WARNING!

- The installation, starting up, and servicing air handling units and their equipment can be hazardous and requires specific knowledge and training.
- Improperly installed, adjusted or altered equipment by an unqualified person could result in death or serious injury.
- When working on the equipment, observe all precautions in the literature and on the tags, stickers, and labels that are attached to the equipment.
- Only qualified personnel should install and service the equipment.

ATTENTION: Warnings, Cautions and Notices appear throughout this document. Read it carefully:

 **WARNING!** Indicates a potentially hazardous situation which, if not avoided, could result in death or serious injury.

 **CAUTION!** Indicates a potentially hazardous situation which, if not avoided, could result in minor or moderate injury. It could also be used to alert against unsafe practices.

 **NOTICE !** Indicates a situation that could result in equipment or property-damage only.

Personal Protective Equipment (PPE) Required!

- ***Before installing/servicing this unit, technicians must put on all Personal Protective Equipment (PPE) recommended for the work being undertaken. Always refer to appropriate MSDS sheets and OSHA guidelines for proper PPE.***
- ***When working with or around hazardous chemicals, ALWAYS refer to the appropriate MSDS sheets and OSHA guidelines for information on allowable personal exposure levels, proper respiratory protection and handling recommendations.***
- ***If there is a risk of arc or flash, technicians MUST put on all Personal Protective Equipment (PPE) in accordance with NFPA 70E or other country-specific requirements for arc flash protection, PRIOR to servicing the unit.***

Failure to follow recommendations could result in death or serious injury.

2 Model Descriptions

The VENTUS air handling units of VTS family are draw-thru air handlers for cooling or/and heating load conditions of 800-38200 cfm. The units are available in either horizontal or vertical configurations. The vertical configurations are limited to 4500 cfm. Both types are typically floor mounted units. All AVS air handling units are intended for indoor and outdoor use. The horizontal devices can be suspended however the manufacturer does not fit the AHU with knockouts.

There is a list of symbols and functions of air handling units:

The horizontal AHU **AVS – XX – L/R – B***, where

The vertical AHU **AVS – XX – L/R – B*(v)**, where

- **AVS** → the product family,
- **XX** → the AHU sizes which are presented as the rounded rated air flow expressed in hundreds of CFM at 480 FPM (2,44 m/s) air velocity on coil.
For exhaust, the unit size is equivalent to an AHU fitted with a coil.
- **L/R** → access (service) side, L – left, R – right
- **B*** → a symbol of a set of functions which are carried out in the device, where:
B* = B₁ / B / B₂
 - B₁ – the symbol of additional functions in the inlet side of the AHU the symbol of basic (predefined) functions (an AHU's BASE). This function is fitted to the AHU outside its,
 - B – the symbol of predefined basic functions' set,
 - B₂ – the symbols of additional functions fixed in the outlet side of the AHU casing,

Table 1 Functions coding











Symbol	Graphic	Function	Options of functions
F		Air filtration	Merv 8 (2") Merv 13 (4")
F- Base		Air filtration	External Box - Merv 8 (2") External Box - Merv 13 (4")
V		Ventilation	Motors' casing: TEFC
C		Cooling (hydronic)	Rows: 4, 6, 8
H		Heating (hydronic)	Hot Water – rows: 1, 2, 3
		Heating (electric)	Draw-through electric heater
M		Mixing (economizer)	In any direction of inlet
S		Silencer	Standard size
P		Recovery with cross-flow exchangers	Standard size
R		Recovery with rotary exchanger	Standard size

Table 2 The coding system of vertical AHUs

Application		Main Function	Code of the main base (set of basic functions)	Functions*
Vertical AHU VTS 8-40 (v) (800-4000 CFM)	SUPPLY	Cooling	C(v)	F-CV
			MC(v)	MFCV
		Heating	H(v)	F-HV
			MH(v)	MFHV
		Heating and Cooling	HC(v)	F-HCV
			MHC(v)	MFHCV
			CH(v)	F-CHV
			CH(v)	F-CV-H
		MCH(v)	MFCHV	

Table 3 AHU coding system

HORIZONTAL AHU VTS 40-380 (4400-38200 CFM)	Application	Main Function	Code of the main base (set of basic functions)	Functions*	
	SUPPLY	Cooling		C	FCV
		Heating		H	FHV
		Heating and Cooling		HC	FHCV
				CH	FCHV
				HCH	FHCVH
	Exhaust	Ventilation	V	V	
			FV	FV	
	Supply Exhaust with energy recovery Cross-Flow Plate	Plate	P	FPV	
		Plate and Cooling	PC	FPCV	
			PC	FPCV	
		Plate and Heating	PH	FPHV	
			PH	FPHV	
		Plate and Heating & Cooling	PHC	FPHCV	
			PCH	FPCHV	
	Supply Exhaust with energy recovery Heat Wheel	Heat Wheel and Heating & Cooling	PCH	FPCVH	
			R	FRV	
			RH	FRHV	
			RC	FRCV	
			RHC	FRHCV	
	RCH	FRCHV			

3 General Information

The VENTUS air handling units of AVS family are draw-thru air handlers for cooling or/and heating load conditions of 800-38200 cfm. The units are available in either horizontal or vertical configurations. The vertical configurations are limited to 4500 cfm. Both types are typically floor mounted units. The horizontal devices can be suspended, however the manufacturer does not fit the AHUs with knockouts. All AVS air handling units are intended for indoor and outdoor use.

The VTS air-handling units are intended for cooperation with a duct ventilation system. Thus access to the rotating parts of the unit (a fan's rotor) is impeded from both positive and negative pressure side of the unit. The ventilation duct system is understood as a net of ventilating ducts.

The majority of AHUs' configuration is available in left-hand access and right-hand access.

Therefore VTS AHUs, denoted by AVS-xx in the model name, have their access panels and coil connections on the same side of the AHU. Therefore, a "Right-handed" AHU will have both its access panel, and its coil connection on the right side (When viewing the unit from the entering air and passing through the supply air section).

There are also available compact AHUs, with coil connections on the side opposite to their access panels.

In case of supply-exhaust units the version is determined by the flow direction of the air through the supply section.

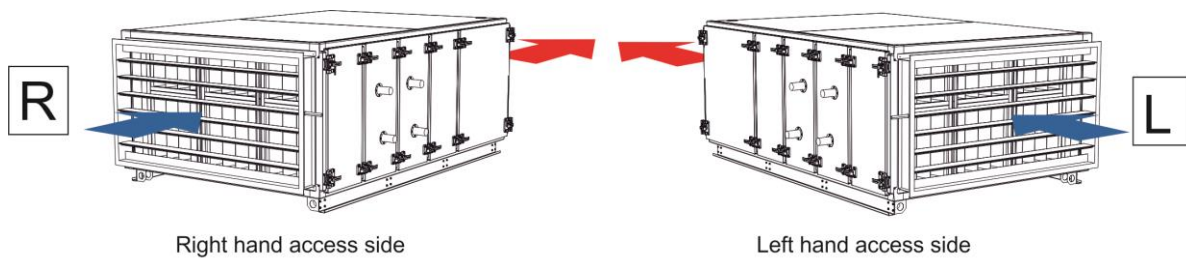

Fig. 1a Handling standard AHUs

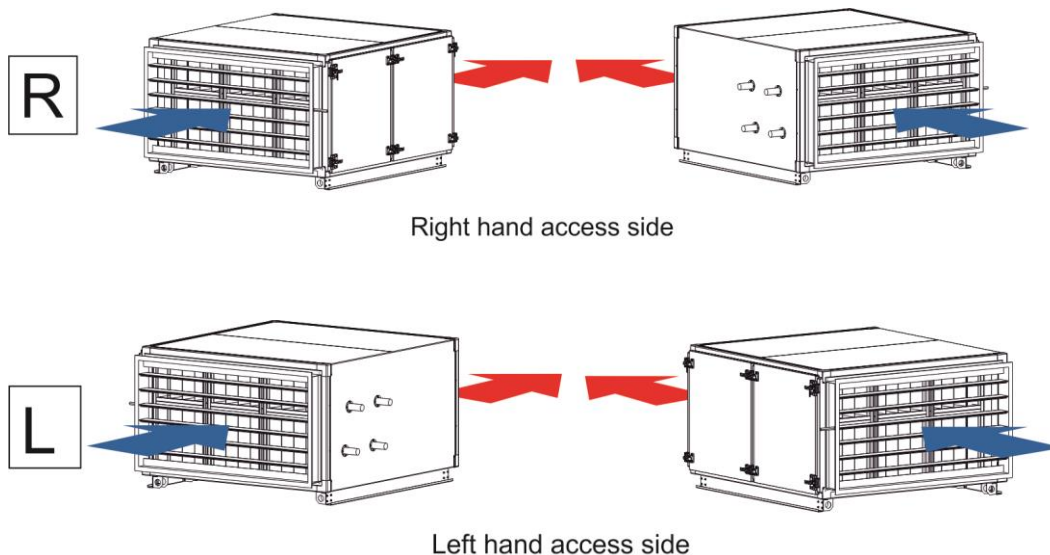

Fig. 2b Handling compac AHUs

The units have a side inlet for easy duct connection, and do not require a field fabricated inlet plenum.

Basic unit components consist of a water coils, condensate drain pan (if applicable), filter, direct drive fan assembly, frequency converter.

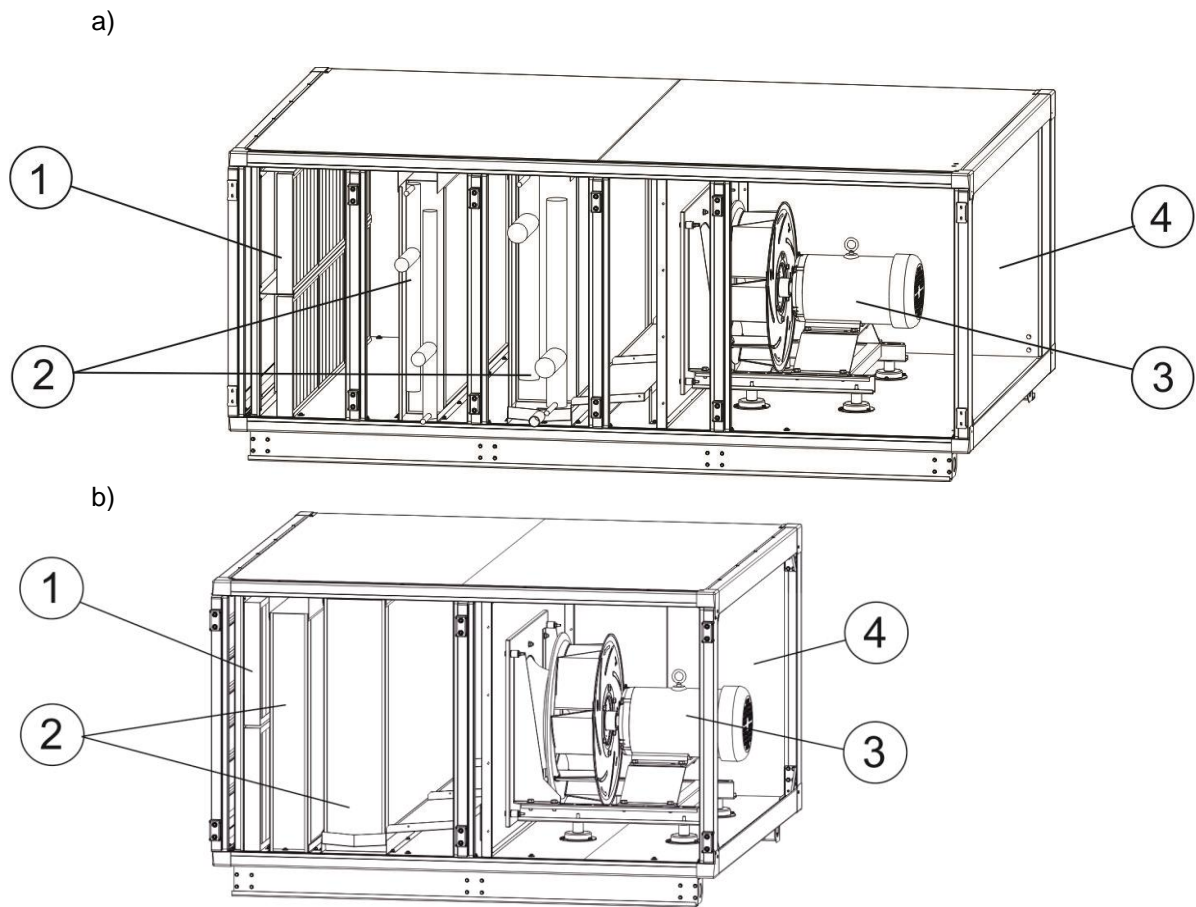

Fig. 3 Basic AHU construction, a) standard unit, b) compact unit: 1 – panel filter, 2- coil, 3 – direct drive plenum fans, 4 – casing

Four, six, or eight-row main coils are available for hydronic cooling and one, two, three-row for heating. Two, three, four, or six-row direct expansion (DX) coils are also available for cooling.

All units have an internal or external flat filter frame for two or four inch filters. All units are fitted with frequency converters as a standard.

Majority of units can have full-plenum inlet and/or outlet or small-plenum inlet and/or outlet (with face panel).

The units can be equipped with duct collars (flanges) on outlet and control system including: valves with actuators, air dampers actuators, temperature sensors, anti-freeze elements, control box with controller, and control panel HMI (Human Machine Interface).

4 Pre-Installation

4.1 Receiving and Handling

The air handling units are packaged for easy handling and storage on the job site. Upon delivery, inspect all components for possible shipping damage. See the "Receiving Checklist" section for detailed instructions. VTS

recommends leaving units and accessories in their shipping packages/skids for protection and handling ease until installation.

The devices should be unloaded and transported to the AHU's installation site using a hand lift or forklift (fig.6) or a crane (fig.7).

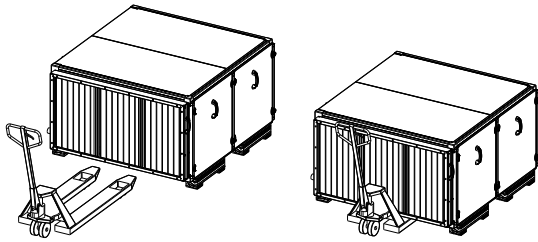

Fig. 4 Using a hand lift to transport the unit

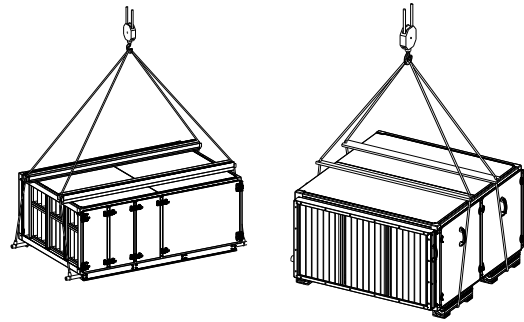

Fig. 5 Transport with the use of a crane

The AHUs have to be transported in their working position and they shall not be stored one on the other. For transport of the units AVS 08-85 with the crane, the holes in the base frame supports can be used in order to mount an appropriate pipe bar. In the case of transport AVS 100-380 units with the use of a crane it is necessary to use holes in the lugs mounted at the ends of base frames. The lugs can be disassembled after placing the AHU in the installation place.

4.1.1 Shipping Package

The air handling unit ships assembled on skids with protective coverings over the coil, frequency converters and discharge openings.

4.1.2 Ship-Separate Accessories

Field-installed control elements (if applicable) ship separately inside a box.

4.1.3 Receiving Checklist

Complete the following checklist immediately after receiving unit shipment to detect possible shipping damage.

- Inspect individual crates before accepting. Check for rattles, bent crates corners, or other visible indications of shipping damage.
- If a unit appears damaged, inspect it immediately before accepting the shipment. Manually rotate the fan wheel to ensure it turns freely. Make specific notations concerning the damage on the freight bill. Do not refuse delivery.
- Inspect the unit for concealed damage before it is stored and as soon as possible after delivery. Report concealed damage to the freight line within the allotted time after delivery. Check with the carrier for their allotted time to submit a claim.
- Do not move damaged material from the receiving location. It is the receiver's responsibility to provide reasonable evidence that concealed damage did not occur after delivery.

- Do not continue unpacking the shipment if it appears damaged. Retain all internal packing, cartons, and crate. Take photos of damaged material if possible.
- Notify the carrier's terminal of the damage immediately by phone and mail. Request an immediate joint inspection of the damage by the carrier and consignee.
- Notify your VTS representative of the damage and arrange for repair. Have the carrier inspect the damage before making any repairs to the unit.
- Compare the electrical data on the unit nameplate with the ordering and shipping information to verify the correct unit is received.

4.1.4 Jobsite Storage Recommendation

The Units and its sections are intended for indoor storage. If indoor storage is not possible, VTS Company recommends the following provisions for outdoor storage:

- Place the unit(s) on a dry surface; ensure adequate air circulation beneath unit and to assure that no portion of the unit contacts standing water at any time.
- Cover the entire unit with a canvas tarp only. Do not use clear, black, or plastic tarps.

The units and their optional components should be stored in the following conditions:

- relative humidity in the room: RH < 80 %
at DB temperature = 68°F

- ambient temperature:
-40°F < DB temperature < +140°F
- The devices should be out of the reach of any caustic dust, gas or steam or any other chemical substances which may have pro-corrosive influence on the unit and its components.

☑ **NOTICE!** *Any damages caused by improper transportation, unloading or storage are not covered by the Warrantee and any claims laid by way of aforementioned issues will not be examined by VTS.*

4.2 Installation Preparation

The **floor mounted unit** shall be placed on:

- A foundation slab,
- A steel base frame concreted into the floor,
- An appropriate stiff steelwork.

The foundation, steel base frame or steelwork have to be flat and leveled and they should be able to support the weight of the unit.

Verify the floor or foundation is level. Repair, if necessary. Make sure proper unit operation; install the unit level (zero tolerance) in both horizontal axes. Failure to level the unit properly can result in improper operation of the unit (e.g. condensate management problems,

higher vibration level, lower heating/cooling capacity)

Provide adequate service clearances as recommended in this document.

The height of the foundation slab or base frame must allow for assembly of the P-trap which drains the condensate out of the draining tray. In case of the drain plates installed in the lower AHU sections, the unit has to be mounted onto an additional foundation slab or a special hollow must be made directly under the P-trap. The minimum height of P-trap is given in the "Draining out condensate" section.

The height of the foundation slab or base frame must allow for assembly of the P-trap which drains the condensate out of the draining tray. In case of the drain plates installed in the lower AHU sections, the unit has to be mounted onto an additional foundation slab or a special hollow must be made directly under the P-trap. The minimum height of P-trap is given in the “Draining out condensate” section.

The **horizontal air handling** units can be installed suspended.

Suspension of units requires external rigging which shall be field-mounted.

Ensure the ceiling opening is large enough for unit installation and maintenance requirements.

The units delivered in sections should be connected by the qualified personnel according to the separate instruction “AVS 8-380 section connection manual”.

During connecting the section one should pay attention on the applying caulk on the casing seams (connecting the sections without using caulk will result in a lack of casing tightness).

4.2.1 Service Access

The AHU shall be installed so that the connections of any related systems (ventilation ducts, pipelines, cabling, etc.) do not collide with the inspection panels.

In order to carry out the operation and maintenance successfully, please keep minimum recommended clearance (Fig.8) between the front side and existing construction elements (walls, pillars, pipelines, etc.)

This is possible to install other systems, pipelines, pillars in the operation area only if they will not hinder the maintenance and service procedures.

The coils are connected on the front side of the unit.

⚠ CAUTION! *It is forbidden to place any elements on the AHU as well as use the AHU as a support of ventilation ducts and any other building components.*

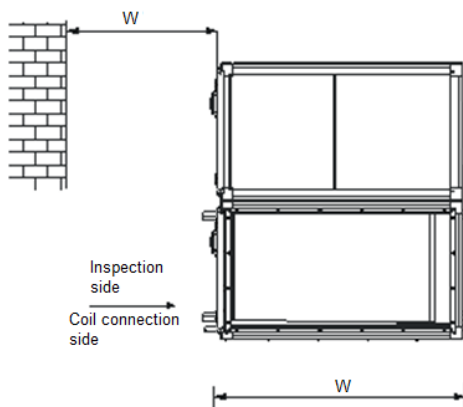

Fig. 6 Inspection Clearance - AVS 8-380

4.2.2 Rigging and Handling

Before preparing the unit for lifting, estimate the approximate center of gravity for lifting safety. Because of placement of internal components, the unit weight may be unevenly distributed, with more weight in the coil area. Approximate unit weights are given in the technical data of AHU and device’s nameplate’. Before hoisting the unit into position, use a proper rigging method such as straps, slings, or spreader bars for protection and safety. Always test-lift the unit to determine the exact unit balance and stability before hoisting it to the installation location. In the case of vertical lifting, all the lifting lugs on the section/unit must be used.

Unit Handling Procedure

1. Position rigging sling under wood skid using spreader bars to avoid unit damage.
2. Use a forklift with caution to prevent unit damage. The fork length must be at least 85 inches long to safely fork the unit from front or back.
3. The unit center of gravity will fall within the center of gravity block at various locations depending on unit options.

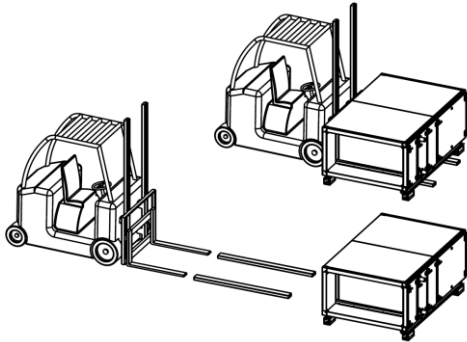

Lifting detail for AVS 8 to 85:

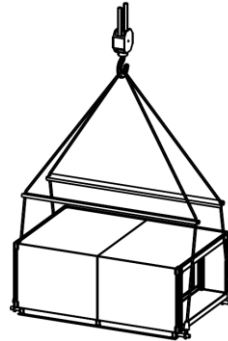

Lifting detail for AVS 100 to 380 by sections:

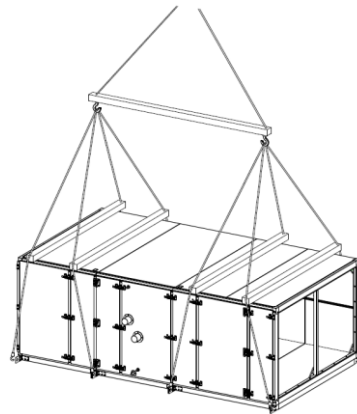
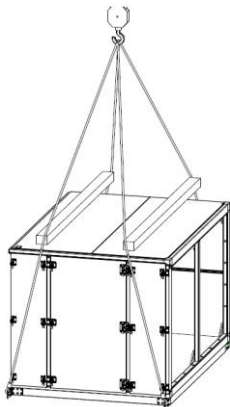

Lifting detail for AVS 100 to 380 with multiple sections:

- ⚠ CAUTION!** When multiple sections jointed/assembled together will be lifted, all lifting lugs must be used.
- ⚠ CAUTION!** Lifting / Rigging material is not provided by VTS.

4.2.3 Unit Location Recommendations

When selecting and preparing the unit installation location, consider the following recommendations.

1. Consider the unit weight. Reference the unit weight on the unit nameplate
2. Allow sufficient space for the recommended clearances, access panel removal, and maintenance access.
3. The installer must provide external rigging for ceiling mounted units.
4. All units must be installed level.
5. Coil piping and condensate drain requirements must be considered.

Allow room for proper ductwork and electrical connections. Support all piping and ductwork independently of unit to prevent excess noise and vibration.

4.2.4 Skid Removal

The unit ships on skids that provide forklift locations from the front or rear. The skid allows easy maneuverability of the unit during storage and transportation. Remove the skids before placing the unit in its permanent location. Remove the skids using a forklift or jack. Lift one end of the unit off of the skids.

4.3 Pre-Installation Checklist

Complete the following checklist before beginning unit installation.

- Verify the unit size and tagging with the unit nameplate.
- Make certain the floor or foundation is level, solid, and sufficient to support the unit and accessory weights. Refer to device's nameplate.
- Level or repair the floor before positioning the unit if necessary.
- Allow minimum recommended clearances for routine maintenance and service. Refer to unit submittals for dimensions.
- Allow one and one half fan diameters above the unit for the discharge ductwork.

5 Dimensions and Weights

Data of weights is given in the AHU nameplate and technical data that is available in the VTS selection software.

5.1 Horizontal AHU

Table 4 Basic dimensions of horizontal AHUs

Size	W	H	Wi	Hi	Hf
	[in]				
AVS 8*	28	22	24	14,5	3,54
AVS 12	38,6	22	34,7	14,5	3,54
AVS 16	44,2	24	40,3	16,5	3,54
AVS 20	46,8	27,2	42,8	19,7	3,54
AVS 30	53,5	32,5	49,6	25	3,54
AVS 40	59,1	37,2	55,1	29,7	3,54
AVS 55	66,1	41,1	62,2	33,7	3,54
AVS 65	75,2	42,6	71,3	35,1	3,54
AVS 85	82,9	46,6	78,9	39,1	3,54
AVS 100	82,9	54,2	78,9	47,1	3,15
AVS 130	98,9	54,2	95	47,1	3,15
AVS 170	102,6	66	98,6	58,9	3,15
AVS 230	122,2	75,2	118,3	68,1	3,15
AVS 300	141,9	75,2	138	68,1	3,15
AVS 380	146,3	93,9	142,4	86,9	3,15

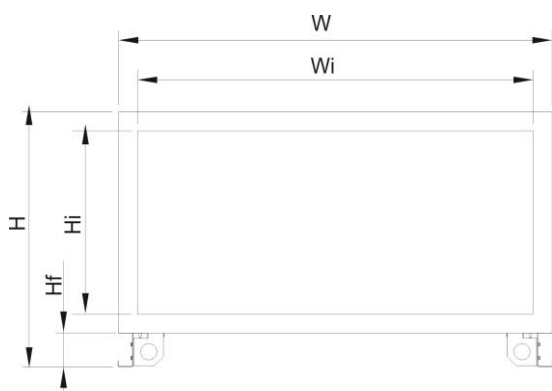

Fig. 6 Horizontal units AVS 8-85

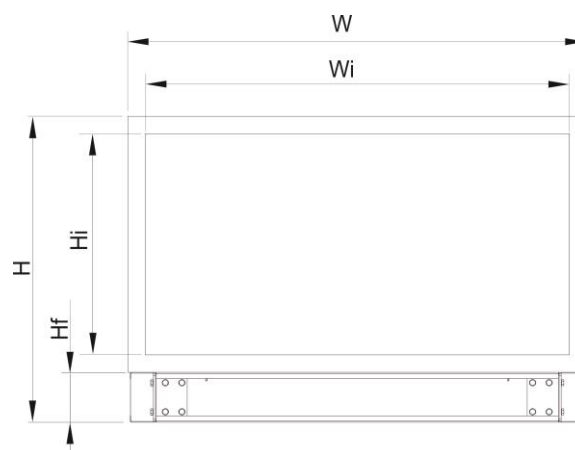

Fig. 7 Horizontal units AVS 100-380

The length "L" of the units depends on the used function and is shown in nameplate and technical data available in the VTS selection software.

Inlet, discharge holes

Table 5 Dimensions of Forward-Full Inlet-Outlet holes

Forward-Full					Dimensions of inlet-outlet holes												
Size	WA	HA	WA1	HA1	Size	WA	HA	WA1	HA1	WB	LB	WB1	LB1	LC	HC	LC1	HC1
	[in]					[in]											
AVS 8	21,65	12,13	3,15	3,15	AVS 8	17,99	7,99	5,04	5,20	17,99	7,95	5,04	4,33	7,99	10,98	4,33	3,73
AVS 12	32,32	12,13	3,15	3,15	AVS 12	25,98	7,99	6,34	5,20	25,98	7,95	6,34	4,33	7,99	10,98	4,33	3,73
AVS 16	37,91	14,17	3,15	3,15	AVS 16	34,02	7,99	5,12	6,22	34,02	7,95	5,12	4,33	7,99	12,99	4,33	3,73
AVS 20	40,47	17,32	3,15	3,15	AVS 20	25,98	12,01	10,43	5,79	25,98	11,93	10,43	4,33	12,01	15,98	4,33	3,83
AVS 30	47,20	22,64	3,15	3,15	AVS 30	34,02	12,01	9,84	8,46	34,02	11,93	9,84	4,33	12,01	20,98	4,33	4,03
AVS 40	52,76	27,36	3,15	3,15	AVS 40	40,47	17,32	9,29	8,19	40,47	17,32	9,29	8,27	14,96	16,26	6,89	8,70
AVS 55	59,84	31,30	3,15	3,15	AVS 55	47,20	22,64	9,49	7,48	47,20	22,64	9,49	5,31	14,96	24,13	6,89	6,73
AVS 65	68,94	32,76	3,15	3,15	AVS 65	47,20	22,64	14,02	8,23	47,20	22,64	14,02	5,31	14,96	24,13	6,89	7,46
AVS 85	76,57	36,73	3,15	3,15	AVS 85	59,84	31,30	11,54	5,87	59,84	31,30	11,54	8,27	29,13	28,07	6,89	7,48
AVS 100	76,57	44,76	3,15	3,15	AVS 100	59,84	31,30	11,54	9,88	59,84	31,30	11,54	8,27	29,13	35,94	6,89	7,56
AVS 130	92,64	44,76	3,15	3,15	AVS 130	76,57	36,73	11,18	7,17	76,57	36,73	11,18	5,31	29,13	35,94	6,89	7,56
AVS 170	96,26	56,54	3,15	3,15	AVS 170	76,57	36,73	12,99	13,07	76,57	36,73	12,99	5,31	29,13	47,76	6,89	7,54
AVS 230	115,94	65,71	3,15	3,15	AVS 230	104,33	36,73	8,98	17,64	104,33	36,73	8,98	5,31	29,13	59,57	6,89	6,22
AVS 300	135,63	65,71	3,15	3,15	AVS 300	124,02	36,73	8,98	17,64	124,02	36,73	8,98	5,31	29,13	59,57	6,89	6,22
AVS 380	140,04	84,49	3,15	3,15	AVS 380	127,95	36,73	9,21	27,05	127,95	36,73	9,21	5,31	29,13	75,31	6,89	7,74

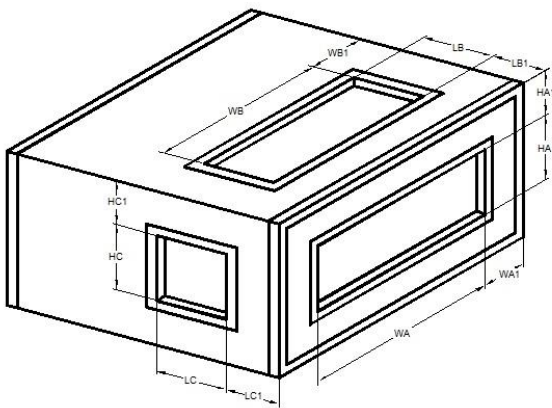

Fig. 8a Inlet, discharge (outlet) holes other than forward-full

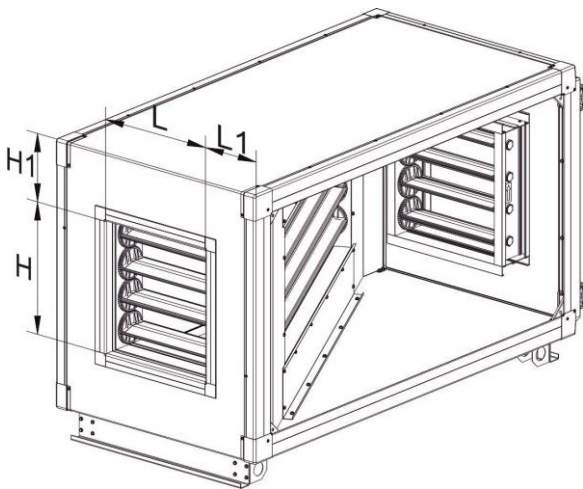

Fig. 8b Inlet, discharge (outlet) holes for economizer

Size	L	H	L1	H1
	[inch]	[inch]	[inch]	[inch]
AVS 8	11	8	9,49	5,20
AVS 12	11	8	9,49	5,20
AVS 16	11	8	9,49	6,26
AVS 20	14,96	12,32	7,52	5,63
AVS 30	14,96	16,26	7,52	6,34
AVS 40	14,96	16,26	7,52	8,70
AVS 55	14,96	24,13	7,52	6,73
AVS 65	14,96	24,13	7,52	7,48
AVS 85	29,13	28,07	7,64	7,48
AVS 100	29,13	35,94	7,64	7,56
AVS 130	29,13	35,94	7,64	7,56
AVS 170	29,13	47,76	7,64	7,56
AVS 230	29,13	59,57	7,64	6,22
AVS 300	29,13	59,57	7,64	6,22
AVS 380	29,13	75,31	7,64	8,11

5.2 Horizontal AHU with Heat Wheel and Cross-Flow Exchanger

Table 6 Basic dimensions of horizontal AHUs with energy recovery system

Size	W	H2	H	Wi	Hi	Hf
	[in]					
AVS 8*	27,95	40,39	21,97	24,02	14,49	3,54
AVS 12	38,62	40,39	21,97	34,69	14,49	3,54
AVS 16	44,21	44,49	24,02	40,28	16,54	3,54
AVS 20	46,77	50,79	27,17	42,83	19,69	3,54
AVS 30	53,50	61,42	32,48	49,57	25,00	3,54
AVS 40	59,06	70,87	37,20	55,12	29,72	3,54
AVS 55	66,14	78,74	41,14	62,20	33,66	3,54
AVS 65	75,24	81,65	42,60	71,30	35,12	3,54
AVS 85	82,87	89,61	46,57	78,94	39,09	3,54
AVS 100	82,87	107,64	54,21	78,94	47,13	3,15
AVS 130	98,94	107,64	54,21	95,00	47,13	3,15
AVS 170	102,56	131,18	65,98	98,62	58,90	3,15
AVS 230	122,24	149,53	75,16	118,31	68,07	3,15
AVS 300	141,93	149,53	75,16	137,99	68,07	3,15
AVS 380	146,34	187,09	93,94	142,40	86,85	3,15

* for unit AVS 8 Heat Wheel is not available

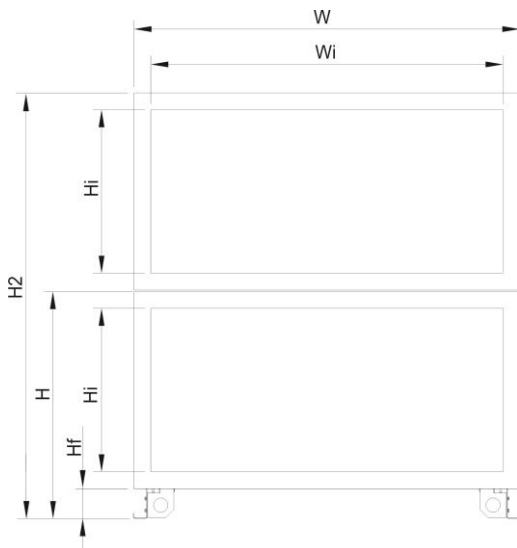

Fig. 9 Horizontal AHUs with energy recovery system – AVS 8 - 85

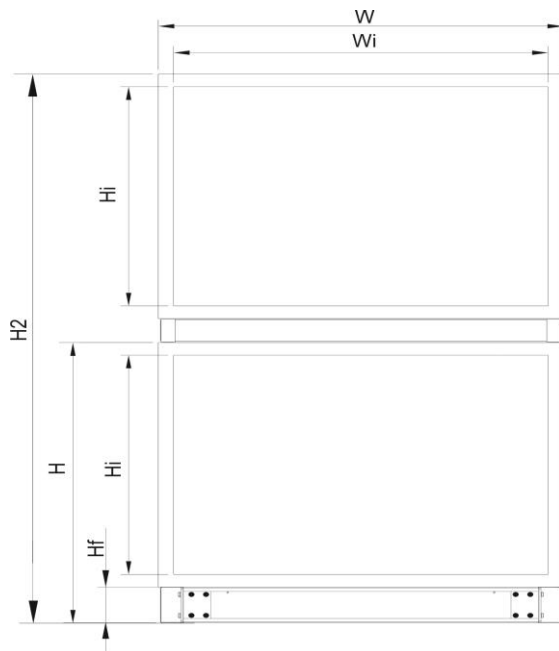

Fig. 10 Horizontal AHUs with energy recovery system – AVS 100 - 380

5.3 Vertical AHU

Table 7 Basic dimensions of vertical AHUs

Size	W	H2	Wi	Hdi	Hui	Hf
	[in]					
AVS 8	27,95	42,05	24,02	14,49	19,69	3,54
AVS 12	38,62	42,05	34,69	14,49	19,69	3,54
AVS 16	44,21	44,09	40,28	16,54	19,69	3,54
AVS 20	46,77	52,56	42,83	19,69	25,00	3,54
AVS 30	53,50	57,87	49,57	25,00	25,00	3,54
AVS 40	59,06	67,32	55,12	29,72	29,72	3,54

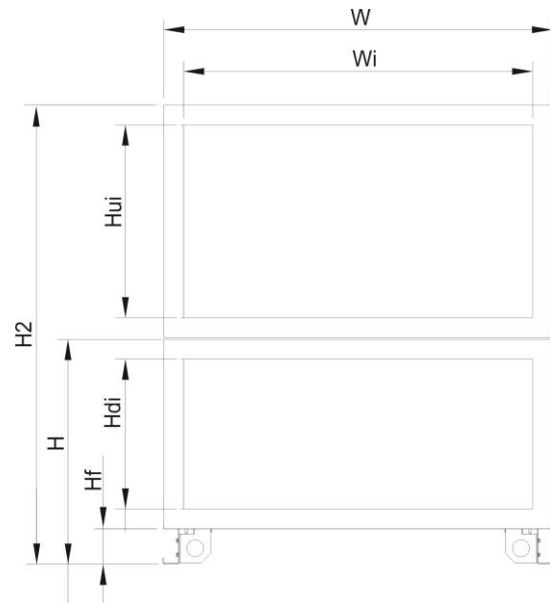

Fig. 11 Vertical AHU – AVS 8-40

5.4 AHU components connection

5.4.1 Hydronic coil exchangers

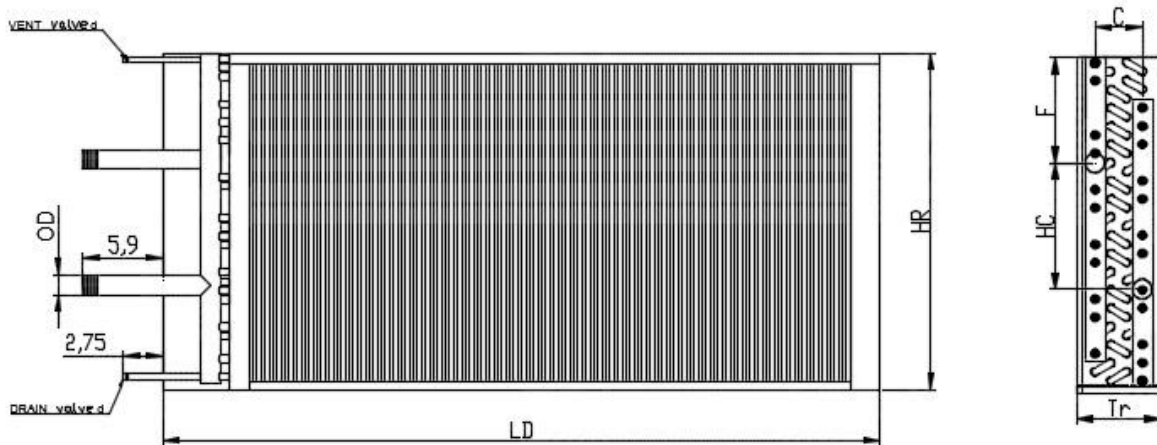

Fig. 12 Dimensions of hydronic coil exchangers AVS 8-170

Table 8 Dimensions of hydronic coil exchangers of AVS 8-170 (Fig. 12)

Coil code	LD	HR	C	HC	TR	OD	d
	[in]						
AVS 8 WCL 1	23,70	12,64	2,36	5,91	4,33	3/4"	1/4"
AVS 8 WCL 2	23,70	12,64	2,36	5,91	4,33	3/4"	1/4"
AVS 8 WCL 3	23,70	12,64	3,25	5,91	5,71	3/4"	1/4"
AVS 8 WCL 4	23,70	12,64	3,25	5,91	5,71	3/4"	1/4"
AVS 8 WCL 6	23,70	12,64	5,41	5,91	7,48	3/4"	1/4"
AVS 8 WCL 8	23,70	12,64	7,58	5,91	9,84	3/4"	1/4"
AVS 12 WCL 1	34,37	12,64	2,28	5,91	4,33	1"	1/4"
AVS 12 WCL 2	34,37	12,64	2,28	5,91	4,33	1"	1/4"
AVS 12 WCL 3	34,37	12,64	3,25	5,91	5,71	1"	1/4"
AVS 12 WCL 4	34,37	12,64	3,25	5,91	5,71	1"	1/4"
AVS 12 WCL 6	34,37	12,64	5,41	5,91	7,48	1"	1/4"
AVS 12 WCL 8	34,37	12,64	7,58	5,91	9,84	1"	1/4"
AVS 20 WCL 1	42,52	17,64	2,28	5,91	4,33	1"	1/4"
AVS 20 WCL 2	42,52	17,64	2,28	5,91	4,33	1"	1/4"
AVS 20 WCL 3	42,52	17,64	3,25	5,91	5,71	1"	1/4"
AVS 20 WCL 4	42,52	17,64	3,25	5,91	5,71	1"	1/4"
AVS 20 WCL 6	42,52	17,64	5,41	5,91	8,46	1 1/4"	1/4"
AVS 20 WCL 8	42,52	17,64	7,58	5,91	9,84	1 1/4"	1/4"
AVS 40 WCL 1	54,8	27,6	2	10,2	4,4	1 1/4"	1/4"
AVS 40 WCL 2	54,8	27,6	2	10,2	4,4	1 1/4"	1/4"
AVS 40 WCL 3	54,8	27,6	3,2	10,2	5,8	1 1/4"	1/4"
AVS 40 WCL 4	54,8	27,6	3,2	10,2	5,8	1 1/4"	1/4"
AVS 40 WCL 6	54,8	27,6	3,2	10,2	7,2	2"	1/4"
AVS 40 WCL 8	54,8	27,6	5,4	10,2	11,3	2"	1/4"
AVS 55 WCL 1	61,9	31,7	2	10,2	4,4	1 1/4"	1/4"
AVS 55 WCL 2	61,9	31,7	2	10,2	4,4	1 1/4"	1/4"
AVS 55 WCL 3	61,9	31,7	3,2	10,2	7,2	2"	1/4"
AVS 55 WCL 4	61,9	31,7	3,2	10,2	7,2	2"	1/4"
AVS 55 WCL 6	61,9	31,7	5,4	10,2	8,5	2"	1/4"
AVS 55 WCL 8	61,9	31,7	5,4	10,2	11,3	3"	1/4"
AVS 65 WCL 1	70,9	33	2	10,2	4,4	1 1/4"	1/4"
AVS 65 WCL 2	70,9	33	2	10,2	4,4	1 1/4"	1/4"
AVS 65 WCL 3	70,9	33	3,2	10,2	7,2	2"	1/4"
AVS 65 WCL 4	70,9	33	3,2	10,2	7,2	2"	1/4"
AVS 65 WCL 6	70,9	33	5,4	10,2	9,9	3"	1/4"
AVS 65 WCL 8	70,9	33	5,4	10,2	11,3	3"	1/4"
AVS 85 WCL 1	78,6	36,9	2	10,2	4,4	1 1/4"	1/4"
AVS 85 WCL 2	78,6	36,9	2	10,2	4,4	1 1/4"	1/4"
AVS 85 WCL 3	78,6	36,9	3,2	10,2	7,2	2"	1/4"
AVS 85 WCL 4	78,6	36,9	3,2	10,2	7,2	2"	1/4"
AVS 85 WCL 6	78,6	36,9	5,4	10,2	9,9	3"	1/4"
AVS 85 WCL 8	78,6	36,9	5,4	10,2	11,3	3"	1/4"
AVS 100 WCL 1	78,6	44,8	3,2	10,2	6,6	2"	1/4"
AVS 100 WCL 2	78,6	44,8	3,2	10,2	8,6	2"	1/4"
AVS 100 WCL 3	78,6	44,8	3,9	10,2	8,6	3"	1/4"
AVS 100 WCL 4	78,6	44,8	3,9	10,2	8,6	3"	1/4"
AVS 100 WCL 6	78,6	44,8	5,4	10,2	10	3"	1/4"
AVS 100 WCL 8	78,6	44,8	5,4	10,2	11,3	2x3"	1/4"
AVS 130 WCL 1	94,7	44,8	3,9	10,2	8,6	2"	1/4"
AVS 130 WCL 2	94,7	44,8	3,9	10,2	8,6	3"	1/4"
AVS 130 WCL 3	94,7	44,8	3,9	10,2	8,6	3"	1/4"
AVS 130 WCL 4	94,7	44,8	3,9	10,2	8,6	3"	1/4"
AVS 130 WCL 6	94,7	44,8	5,4	10,2	10	3"	1/4"
AVS 130 WCL 8	94,7	44,8	5,4	10,2	11,3	2x3"	1/4"
AVS 170 WCL 1	98,3	56,7	3,9	10,2	8,6	3"	1/4"
AVS 170 WCL 2	98,3	56,7	3,9	10,2	8,6	3"	1/4"
AVS 170 WCL 3	98,3	56,7	3,9	10,2	8,6	3"	1/4"
AVS 170 WCL 4	98,3	56,7	3,9	10,2	8,6	3"	1/4"
AVS 170 WCL 6	98,3	56,7	5,4	10,2	10	3"	1/4"
AVS 170 WCL 8	98,3	56,7	5,4	10,2	11,3	2x3"	1/4"

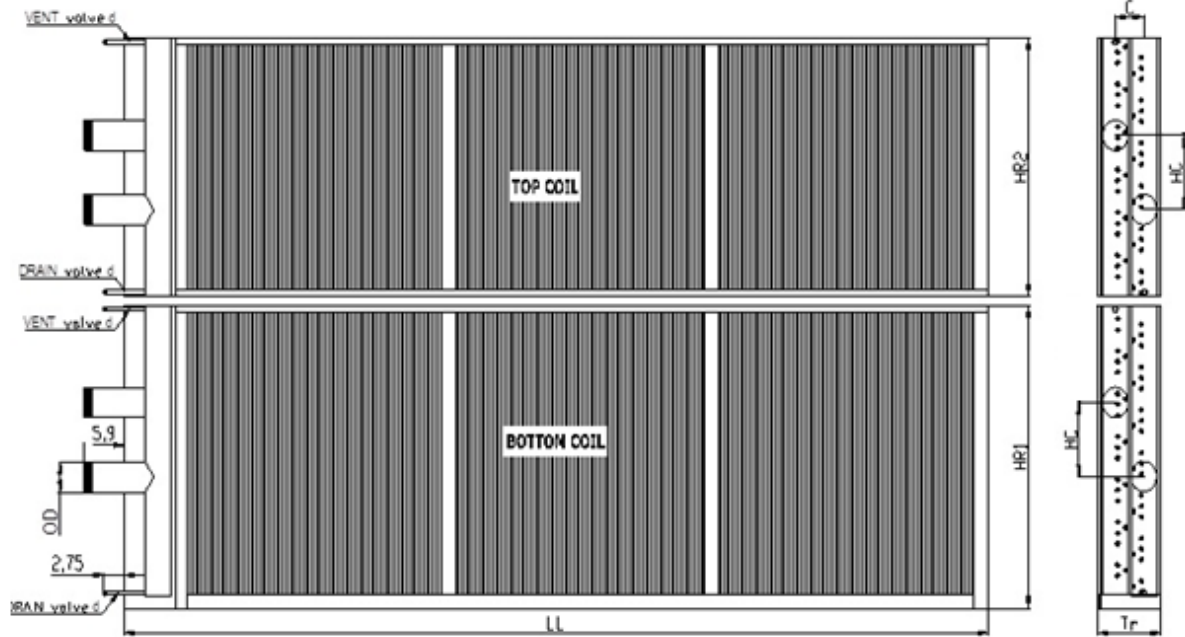

Fig. 13 Dimensions of hydronic coil exchangers AVS 230-380

Table 9 Dimensions of hydronic coil exchangers of AVS 230-380 (Fig. 13)

Coil code	LD	HR1	HR2	C	HC	Tr	OD	d
	[in]							
AVS 230 WCL 1	118,0	32,5	32,5	3,9	10,2	8,6	3"	1/4"
AVS 230 WCL 2	118,0	32,5	32,5	3,9	10,2	8,6	3"	1/4"
AVS 230 WCL 3	118,0	32,5	32,5	3,9	10,2	8,6	3"	1/4"
AVS 230 WCL 4	118,0	32,5	32,5	3,9	10,2	8,6	3"	1/4"
AVS 230 WCL 6	118,0	32,5	32,5	5,4	10,2	10,0	3"	1/4"
AVS 230 WCL 8	118,0	32,5	32,5	5,4	10,2	11,3	3"	1/4"
AVS 300 WCL 1	137,7	32,6	32,6	3,9	10,2	8,6	3"	1/4"
AVS 300 WCL 2	137,7	32,6	32,6	3,9	10,2	8,6	3"	1/4"
AVS 300 WCL 3	137,7	32,6	32,6	3,9	10,2	8,6	3"	1/4"
AVS 300 WCL 4	137,7	32,6	32,6	3,9	10,2	8,6	3"	1/4"
AVS 300 WCL 6	137,7	32,6	32,6	5,4	10,2	10,0	3"	1/4"
AVS 300 WCL 8	137,7	32,6	32,6	5,4	10,2	11,4	3"	1/4"
AVS 380 WCL 1	142,1	41,9	41,9	3,9	10,2	8,6	3"	1/4"
AVS 380 WCL 2	142,1	41,9	41,9	3,9	10,2	8,6	3"	1/4"
AVS 380 WCL 3	142,1	41,9	41,9	3,9	10,2	8,6	3"	1/4"
AVS 380 WCL 4	142,1	41,9	41,9	3,9	10,2	8,6	3"	1/4"
AVS 380 WCL 6	142,1	41,9	41,9	5,4	10,2	10,0	3"	1/4"
AVS 380 WCL 8	142,1	41,9	41,9	5,4	10,2	11,4	3"	1/4"

5.4.2 DX Coils

One-circuit (One-section) DX coils

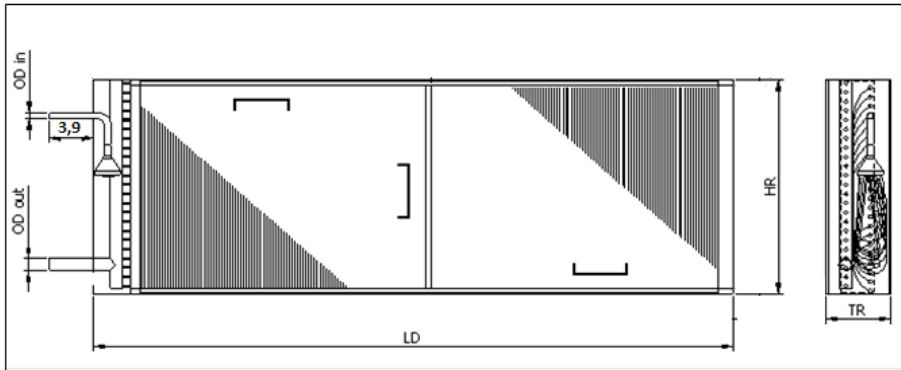

Fig. 14 One-circuit (One-section) DX coil drawing

Table 10 Dimensions of one-circuit (one-section) DX coils (Fig. 14)

Coil code	LD	HR	TR	ØD In	ØD out
	AVS 8 DXH 2-1.	23,70	12,64	4,33	5/8"
AVS 8 DXH 3-1.	23,70	12,64	5,71	5/8"	7/8"
AVS 8 DXH 4-1.	23,70	12,64	5,71	5/8"	7/8"
AVS 8 DXH 6-1.	23,70	12,64	8,46	5/8"	7/8"
AVS 12 DXH 2-1.	34,37	12,64	4,33	5/8"	1 1/8"
AVS 12 DXH 3-1.	34,37	12,64	5,71	5/8"	1 1/8"
AVS 12 DXH 4-1.	34,37	12,64	7,09	5/8"	1 1/8"
AVS 12 DXH 6-1.	34,37	12,64	9,84	7/8"	1 1/8"
AVS 16 DXH 2-1.	39,96	14,57	4,33	5/8"	1 1/8"
AVS 16 DXH 3-1.	39,96	14,57	5,71	5/8"	1 1/8"
AVS 16 DXH 6-1.	39,96	14,57	8,46	5/8"	1 1/8"
AVS 20 DXH 2-1.	42,52	17,64	5,71	7/8"	1 3/8"
AVS 20 DXH 3-1.	42,52	17,64	5,71	5/8"	1 1/8"
AVS 20 DXH 4-1.	42,52	17,64	7,09	7/8"	1 3/8"
AVS 20 DXH 6-1.	42,52	17,64	9,84	7/8"	1 3/8"
AVS 30 DXH 2-1.	49,25	23,11	4,33	7/8"	1 1/8"
AVS 30 DXH 3-1.	49,25	23,11	5,71	7/8"	1 3/8"
AVS 30 DXH 4-1.	49,25	23,11	7,09	7/8"	1 5/8"
AVS 30 DXH 6-1.	49,25	23,11	9,84	7/8"	1 5/8"
AVS 40 DXH 2-1.	54,80	27,64	4,33	5/8"	1 1/8"
AVS 40 DXH 3-1.	54,80	27,64	5,71	7/8"	1 1/8"
AVS 40 DXH 4-1.	54,80	27,64	7,09	7/8"	1 3/8"
AVS 40 DXH 6-1.	54,80	27,64	9,84	7/8"	1 5/8"
AVS 55 DXH 2-1.	61,89	31,73	4,33	7/8"	1 1/8"
AVS 55 DXH 3-1.	61,89	31,73	5,71	7/8"	1 3/8"
AVS 55 DXH 4-1.	61,89	31,73	7,09	1 1/8"	1 5/8"
AVS 65 DXH 2-1.	70,94	32,99	5,71	7/8"	1 3/8"
AVS 65 DXH 3-1.	70,94	32,99	5,71	7/8"	1 5/8"
AVS 65 DXH 4-1.	70,94	32,99	7,09	7/8"	1 5/8"
AVS 85 DXH 2-1.	78,62	36,89	5,71	7/8"	1 3/8"
AVS 85 DXH 3-1.	78,62	36,89	7,09	7/8"	1 5/8"
AVS 85 DXH 4-1.	78,62	36,89	8,46	7/8"	2 1/8"
AVS 100 DXH 2-1.	78,62	44,76	5,71	7/8"	1 5/8"
AVS 100 DXH 3-1.	78,62	44,76	7,09	7/8"	2 1/8"

Two-circuit (Two-section) DX coils

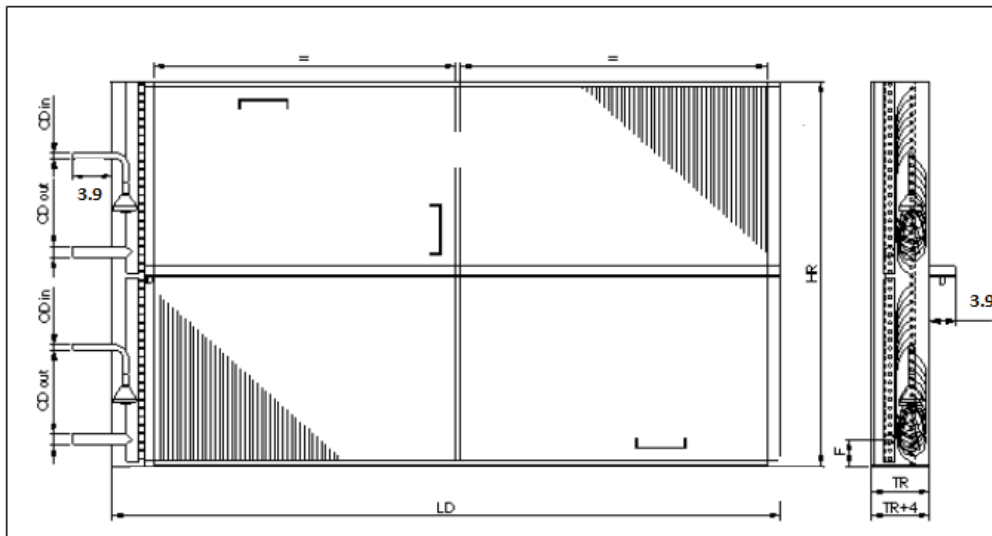

Fig. 15 Two-circuit (Two-section) DX coil drawing

Table 11 Two-circuit (Two-section) DX coil (Fig. 15)

Coil code	LD	HR	TR	ØD In	ØD out
	[in]				
AVS 16 DXH 6-2.	39,96	14,57	8,46	2x5/8"	2x1 1/8"
AVS 20 DXH 4-2.	42,52	17,64	7,09	2x5/8"	2x1 1/8"
AVS 20 DXH 6-2.	42,52	17,64	9,84	2x5/8"	2x1 1/8"
AVS 30 DXH 3-2.	49,25	23,11	5,71	2x5/8"	2x1 1/8"
AVS 30 DXH 4-2.	49,25	23,11	7,09	2x5/8"	2x1 1/8"
AVS 30 DXH 6-2.	49,25	23,11	9,84	2x7/8"	2x1 3/8"
AVS 40 DXH 3-2.	54,80	27,64	5,71	2x5/8"	2x1 1/8"
AVS 40 DXH 4-2.	54,80	27,64	7,09	2x5/8"	2x1 1/8"
AVS 40 DXH 6-2.	54,80	27,64	9,84	2x7/8"	2x1 1/8"
AVS 55 DXH 2-2.	61,89	31,73	4,33	2x5/8"	2x1 1/8"
AVS 55 DXH 3-2.	61,89	31,73	5,71	2x5/8"	2x1 1/8"
AVS 55 DXH 4-2.	61,89	31,73	7,09	2x7/8"	2x1 1/8"
AVS 55 DXH 6-2.	61,89	31,73	9,84	2x7/8"	2x1 3/8"
AVS 65 DXH 2-2.	70,94	32,99	4,33	2x5/8"	2x1 1/8"
AVS 65 DXH 3-2.	70,94	32,99	5,71	2x5/8"	2x1 1/8"
AVS 65 DXH 4-2.	70,94	32,99	7,09	2x7/8"	2x1 1/8"
AVS 65 DXH 6-2.	70,94	32,99	9,84	2x7/8"	2x1 3/8"
AVS 85 DXH 2-2.	78,62	36,89	4,33	2x5/8"	2x1 1/8"
AVS 85 DXH 3-2.	78,62	36,89	5,71	2x7/8"	2x1 3/8"
AVS 85 DXH 4-2.	78,62	36,89	7,09	2x7/8"	2x1 3/8"
AVS 85 DXH 6-2.	78,62	36,89	9,84	2x7/8"	2x1 5/8"
AVS 100 DXH 2-2.	78,62	44,76	5,71	2x7/8"	2x1 3/8"
AVS 100 DXH 3-2.	78,62	44,76	5,71	2x7/8"	2x1 1/8"

Coil code	LD	HR	TR	ØD In	ØD out
	[in]				
AVS 100 DXH 4-2.	78,62	44,76	7,09	2x7/8"	2x1 5/8"
AVS 100 DXH 6-2.	78,62	44,76	9,84	2x7/8"	2x1 5/8"
AVS 130 DXH 2-2.	94,69	44,76	5,71	2x7/8"	2x1 3/8"
AVS 130 DXH 3-2.	94,69	44,76	5,71	2x7/8"	2x1 3/8"
AVS 130 DXH 4-2.	94,69	44,76	8,46	2x7/8"	2x2 1/8"
AVS 130 DXH 6-2.	94,69	44,76	11,22	2x1 1/8"	2x2 1/8"
AVS 170 DXH 2-2.	98,31	56,73	5,71	2x7/8"	2x1 5/8"
AVS 170 DXH 3-2.	98,31	56,73	5,71	2x7/8"	2x1 5/8"
AVS 170 DXH 4-2.	98,31	56,73	8,46	2x7/8"	2x2 1/8"
AVS 170 DXH 6-2.	98,31	56,73	11,22	2x1 1/8"	2x2 1/8"
AVS 230 DXH 2-2.	117,99	65,47	5,71	2x7/8"	2x1 5/8"
AVS 230 DXH 3-2.	117,99	65,47	5,71	2x1 1/8"	2x1 5/8"
AVS 230 DXH 4-2.	117,99	65,47	8,46	2x1 1/8"	2x2 1/8"
AVS 230 DXH 6-2.	117,99	65,47	11,22	2x1 3/8"	2x2 1/8"
AVS 300 DXH 2-2.	137,68	65,20	5,71	2x1 1/8"	2x1 5/8"
AVS 300 DXH 3-2.	137,68	65,20	7,09	2x1 1/8"	2x2 5/8"
AVS 300 DXH 4-2.	137,68	65,20	8,46	2x1 3/8"	2x2 1/8"
AVS 300 DXH 6-2.	137,68	65,20	11,22	2x1 3/8"	2x3 1/8"
AVS 380 DXH 2-2.	142,09	83,98	5,71	2x7/8"	2x1 5/8"
AVS 380 DXH 3-2.	142,09	83,98	7,09	2x1 3/8"	2x2 5/8"
AVS 380 DXH 4-2.	142,09	83,98	8,46	2x1 3/8"	2x3 1/8"
AVS 380 DXH 6-2.	142,09	83,98	11,22	2x1 5/8"	2x3 1/8"

5.4.3 Electric Heaters

The main supply is to be connected to the electric heater main switch, mounted on its casing side inside the unit. Electric heater supply wiring should be let through the fixed panel, at the AHU's back. If the wiring is led through the inspection panel, on the front side, then it should be arranged so as to enable opening the section for maintenance and service operations.

Available heater power output depending on the connection type and number of heating elements are shown in the table 13 – 16.

5.4.4 Air Filters

Pleated panel filters in two filtration classes MERV /8/13 and nominal sizes 2" and 4" respectively.

Table 12 Panel filters sizes

AHU size	MERV 8 (2") C=2"		MERV 13 (4") C=4"	
	WxH [inch]	Qty	WxH [inch]	Qty
AVS 8	24 x 14,25	1	24 x 14,25	1
AVS 12	14,25 x 17,35	2	14,25 x 17,35	2
AVS 16	15,5 x 19,5	2	15,5 x 19,5	2
AVS 20	19,5 x 19,5	1	19,5 x 19,5	1
	19,375 x 23,375	1	19,375 x 23,375	1
AVS 30	15,5 x 24,5	3	15,5 x 24,5	3
AVS 40	14,25 x 17,35	6	14,25 x 17,35	6
AVS 55	15,5 x 19,5	6	15,5 x 19,5	6
AVS 65	15,375 x 23,375	6	15,375 x 23,375	6
AVS 85	17,5 x 24,5	3	17,5 x 24,5	3
	19,5 x 24,5	3	19,5 x 24,5	3
AVS 100	19,5 x 19,5	4	19,5 x 19,5	4
	19,5 x 24,5	4	19,5 x 24,5	4
AVS 130	19,375 x 23,375	4	19,375 x 23,375	4
	23,375 x 23,375	4	23,375 x 23,375	4
AVS 170	15,5 x 24,5	4	15,5 x 24,5	4
	19,5 x 24,5	8	19,5 x 24,5	8
AVS 230	15,5 x 19,5	6	15,5 x 19,5	6
	19,5 x 24,5	12	19,5 x 24,5	12
AVS 300	15,5 x 19,5	7	15,5 x 19,5	7
	19,5 x 24,5	14	19,5 x 24,5	14
AVS 380	19,375 x 23,375	12	19,375 x 23,375	12
	23,375 x 23,375	12	23,375 x 23,375	12

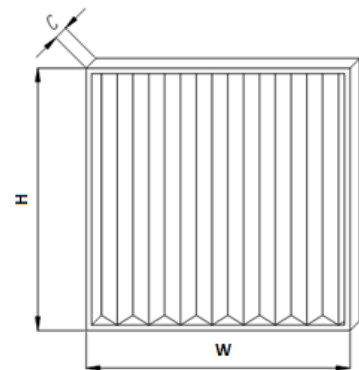

6 Installation of Variable Frequency Drive (Frequency Converter)

A variable frequency drive is an integral part of each fan section. It is factory mounted and comes as a standard equipment of the air handling unit. Before beginning installation, follow the wiring instructions given in this document. Especially, refer to the unit wiring schematic for specific wiring details (see the section 7 in this document).

Notes on Installation

Avoid placing VFD devices in the area, which is subject to the following conditions:

- Radiant heat from the sun, fireplaces, other appliances, etc.
- Direct sunlight exposure.
- Fog, fumes, oil mist or other exhaust from kitchen appliances or industrial processes.
- Dripping water from humidity condensation or any other source.

7 Installation: Electrical

7.1 Unit Wiring Diagrams

Specific unit wiring diagrams are provided on the inside of the unit. Typical unit wiring diagrams is given below. Use these diagrams for connections or trouble analysis.

⚠ WARNING! Before starting connecting power supply, check conformity of the voltage and frequency of a supply network with the data shown on the device's rating plate. Permissible fluctuation of the supply voltage and its frequency to the values shown on the rating plate is $\pm 5\%$. If discrepancy exists, the device cannot be connected.

⚠ WARNING! Hazardous Voltage! Disconnect all electric power, including remote disconnects before servicing. Follow proper lockout procedures to ensure the power cannot be inadvertently energized. Failure to disconnect power before servicing could result in death or serious injury.

⚠ WARNING! Proper Field Wiring and Grounding Required! All field wiring **MUST** be performed by qualified personnel. Improperly installed and grounded field wiring poses **FIRE** and **ELECTROCUTION** hazards. To avoid these hazards, you **MUST** follow requirements for field wiring installation and grounding as described in **NEC** and your local/state electrical codes. Failure to follow code could result in death or serious injury.

⚠ WARNING! Correct Phase Critical! Correct phase sequence is critical. If phase sequence of the incoming line voltage is not correct, it could cause motor damage.

⚠ WARNING! Use only copper-core wires!

7.2 Power Supply Wiring

✔ **Notice:** Wiring must conform to **NEC** and all applicable code requirements.

It is the installer's responsibility to provide adequately-sized power wires and proper unit grounding. Equipment submittals should be referred to for the exact electrical access. Connect the power wires to the power connection point provided (frequency converter's, electric heater's terminal box, control box's terminal).

Connection to the installer-provided ground path must be made to the green wire or green grounding screw provided on each unit. Locate unit wiring diagrams inside device. Refer to the unit-specific wiring diagrams for wiring, connection point, and fuse installation information. Refer to the unit nameplate for unit-specific electrical information, such as voltage, full loads amps. (FLA), maximum circuit breaker (MAX.CKT.BKR).

7.3 Electrical Connections

The main supply is to be field connected by the installer with:

- **Fan's frequency converters** which are factory mounted in the AHU (to energize the fan sets' electric motors).
Power and ground are tucked inside of the frequency converters box.
- **Electric heater terminal block** that is factory mounted on the AHU (to energize the electric heaters that are embedded inside the AHU).
Power and ground connections are tucked inside the electric heat terminal block.
- **Heat wheel's frequency converter** that is factory mounted inside the AHU - to energize the heat wheel's (rotary regenerator's) electric motors.
Power and ground connections are inside the electric heat terminal box,
- **Control box that is intended for field mounting** -to energize the control elements and control's system. Power and ground connections are tucked inside the control box.

Specific unit wiring diagrams are provided on the inside of the control panel door. Typical unit wiring diagrams are in the "Wiring Diagrams". Use these diagrams for connections or trouble analysis

7.4 Electrical Grounding Restrictions

All sensor and input circuits are normally at or near ground (common) potential. When wiring sensors and other input devices to the controller, avoid creating ground loops with grounded conductors external to the unit control circuit. Ground loops can affect the measurement accuracy of the controller.

All input/output circuits (except isolated relay contacts and optically-isolated inputs) assume a grounded source, either a ground wire at the supply transformer to control panel chassis, or an installer supplied ground.

☑ **NOTICE!** Do not connect any sensor or input circuit to an external ground connection.

The installer must provide interconnection wiring to connect wall mounted devices such as a zone sensor module. Refer to the unit

wiring schematic for specific wiring details and point-to-point wiring connections.

Dashed lines indicate field wiring on the unit wiring schematics. All interconnection wiring must conform to NEC Class 2 wiring requirements and any state and local requirements.

☑ **NOTICE!** Do not bundle or run interconnection wiring in parallel with or in the same conduit with any high voltage wires (110V or greater). Exposure of interconnection wiring to high voltage wiring, inductive loads, or RF transmitters may cause radio frequency interference (RFI). In addition, improper separation may cause electrical noise problems. Therefore, use shielded wire (Beldon 83559/83562 or equivalent) in applications that require a high degree of noise immunity. Connect the shield to the chassis ground and tape at the other end.

7.5 Full Load Amps and Maximum Circuit Breaker.

7.5.1 Electric Heater.

Use data that is given below to select relevant wires and to select relevant size of fuses.

Table 13 Electric Heaters 1/208 [V] and 1/230 [V] (60 Hz)

Unit type&size	Voltage	P(N1)	Pn				FLA				MCB			
			Total nominal power of the heater at desired power supply voltage				Full load amperes				Max Circuit Breaker			
	[V/f/ Hz]	[kW]	P(N1) [kW]	P(N2) [kW]	P(N3) [kW]	P(N4) [kW]	I(N1) [A]	I(N2) [A]	I(N3) [A]	I(N4) [A]	I(N1) [A]	I(N2) [A]	I(N3) [A]	I(N4) [A]
			1	2	3	4	1	2	3	4	1	2	3	4
AVS 8	208/1/60	2,45	2,45	4,90	7,35		11,78	23,56	35,34		15	30	45	
AVS 12	208/1/60	2,45	2,45	4,90	7,35	9,80	11,78	23,56	35,34	47,12	15	30	45	60
AVS 16	208/1/60	2,45	2,45	4,90	7,35	9,80	11,78	23,56	35,34	47,12	15	30	45	60
AVS 20	208/1/60	2,45		4,90	7,35	9,80		23,6	35,3	47,12		30	45	60
AVS 30	208/1/60	2,45		4,90	7,35	9,80		23,6	35,3	47,12		30	45	60
AVS 40	208/1/60	4,91		9,82				47,21				60		
AVS 55	208/1/60	4,91			14,73	19,64			70,82	94,42			90	125
AVS 65	208/1/60	4,91			14,73	19,64			70,82	94,42			90	125
AVS 85	208/1/60	4,91				19,64				94,42				125
AVS 8	230/1/60	3,00	3,0	6,0	9,0		13,04	26,09	39,13		20	35	50	
AVS 12	230/1/60	3,00	3,0	6,0	9,0	12,0	13,04	26,09	39,13	52,17	20	35	50	70
AVS 16	230/1/60	3,00	3,0	6,0	9,0	12,0	13,04	26,09	39,13	52,17	20	35	50	70
AVS 20	230/1/60	3,00		6,0	9,0	12,0		26,09	39,13	52,17		35	50	70
AVS 30	230/1/60	3,00		6,0	9,0	12,0		26,09	39,13	52,17		35	50	70
AVS 40	230/1/60	6,00		12,0				52,17				70		
AVS 55	230/1/60	6,00			18,0	24,0			78,26	104,35			100	150
AVS 65	230/1/60	6,00			18,0	24,0			78,26	104,35			100	150
AVS 85	230/1/60	6,00				24,0				104,35				150

Table 14 Electric Heaters 3/208 [V] and 3/230 [V] (60Hz)

Unit type & size	Voltage	P(N1)	Pn									FLA\									MCB																		
			Total nominal power of the heater at desired power supply voltage									Full load amperes									Max Circuit Breaker																		
			P(N1) [kW]	P(N2) [kW]	P(N3) [kW]	P(N4) [kW]	P(N5) [kW]	P(N6) [kW]	P(N7) [kW]	P(N8) [kW]	P(N9) [kW]	I(N1) [A]	I(N2) [A]	I(N3) [A]	I(N4) [A]	I(N5) [A]	I(N6) [A]	I(N7) [A]	I(N8) [A]	I(N9) [A]	I(N1) [A]	I(N2) [A]	I(N3) [A]	I(N4) [A]	I(N5) [A]	I(N6) [A]	I(N7) [A]	I(N8) [A]	I(N9) [A]										
AVS 8	208/3/60	2,45	2,45	4,90	7,35															15	15	30	30	30															
AVS 12	208/3/60	2,45	2,45	4,90	7,35	9,80														15	15	30	30	30	40														
AVS 16	208/3/60	2,45	2,45	4,90	7,35	9,80	12,25													15	15	30	30	30	40	60													
AVS 20	208/3/60	2,45	2,45	4,90	7,35	9,80	12,25	14,70																		60													
AVS 30	208/3/60	2,45	2,45	4,90	7,35	9,80	12,25	14,70																		60													
AVS 40	208/3/60	4,91	4,91	9,82	14,73	19,64																				60													
AVS 55	208/3/60	4,91	4,91	9,82	14,73	19,64	24,55	29,46																		60													
AVS 65	208/3/60	4,91	4,91	9,82	14,73	19,64	24,55	29,46																		60													
AVS 85	208/3/60	4,91	4,91	9,82	14,73	19,64	24,55	29,46																		80													
AVS 100	208/3/60	4,91	4,91	9,82	14,73	19,64	24,55	29,46	34,37																	80													
AVS 130	208/3/60	4,91	4,91	9,82	14,73	19,64	24,55	29,46	34,37	39,28																110													
AVS 170	208/3/60	4,91	4,91	9,82	14,73	19,64	24,55	29,46	34,37	44,19																110													
AVS 230	208/3/60	4,91	4,91	9,82	14,73	19,64	24,55	29,46	34,37	44,19																110													
AVS 8	230/3/60	3,00	3,00	6,00	9,00																					20													
AVS 12	230/3/60	3,00	3,00	6,00	9,00	12,00																				20													
AVS 16	230/3/60	3,00	3,00	6,00	9,00	12,00	15,00																			20													
AVS 20	230/3/60	3,00	3,00	6,00	9,00	12,00	15,00	18,00																		30													
AVS 30	230/3/60	3,00	3,00	6,00	9,00	12,00	15,00	18,00																		30													
AVS 40	230/3/60	6,00	6,00	12,00	18,00																					60													
AVS 55	230/3/60	6,00	6,00	12,00	18,00	24,00																				60													
AVS 65	230/3/60	6,00	6,00	12,00	18,00	24,00	30,00																			60													
AVS 85	230/3/60	6,00	6,00	12,00	18,00	24,00	30,00	36,00																		90													
AVS 100	230/3/60	6,00	6,00	12,00	18,00	24,00	30,00	36,00	42,00																	90													
AVS 130	230/3/60	6,00	6,00	12,00	18,00	24,00	30,00	36,00	42,00	48,00																113,7													
AVS 170	230/3/60	6,00	6,00	12,00	18,00	24,00	30,00	36,00	42,00	48,00	54,00															135,6													
AVS 230	230/3/60	6,00	6,00	12,00	18,00	24,00	30,00	36,00	42,00	48,00	54,00															135,6													

Table 15 Electric Heaters 3x380 [V] (50 and 60 Hz) with heater element number 1-8

Unit type&size	Voltage	P (N1) [kW]	Pn								FLA								MCB								
			Total nominal power of the heater at desired power supply voltage								Full load amperes								Max Circuit Breaker								
			P (N1) [kW]	P (N2) [kW]	P (N3) [kW]	P (N4) [kW]	P (N5) [kW]	P (N6) [kW]	P (N7) [kW]	P (N8) [kW]	I (N1) [A]	I (N2) [A]	I (N3) [A]	I (N4) [A]	I (N5) [A]	I (N6) [A]	I (N7) [A]	I (N8) [A]	I (N1) [A]	I (N2) [A]	I (N3) [A]	I (N4) [A]	I (N5) [A]	I (N6) [A]	I (N7) [A]	I (N8) [A]	
	[V/f/Hz]	[kW]	1	2	3	4	5	6	7	8	1	2	3	4	5	6	7	8	1	2	3	4	5	6	7	8	
AVS 8	380/3/50	2,05	2,05	4,10	6,15						5,4	9,3	9,3						15	15	15						
AVS 12	380/3/50	2,05	2,05	4,10	6,15	8,20					5,4	9,3	9,3	14,3					15	15	15	20					
AVS 16	380/3/50	2,05	2,05	4,10	6,15	8,20	10,25				5,4	9,3	9,3	14,3	18,7				15	15	15	20	25				
AVS 20	380/3/50	2,05		4,10	6,15	8,20	10,25	12,30				9,3	9,3	14,3	18,7	18,7				15	15	15	20	25	25		
AVS 30	380/3/50	2,05		4,10	6,15	8,20	10,25	12,30	14,35	16,40		9,3	9,3	14,3	18,7	18,7	23,5			15	15	15	20	25	25	30	40
AVS 40	380/3/50	4,10		8,20	12,30	16,40	20,50	24,60				18,7	18,7	28,5	37,4	37,4				25	25	40	50	50	50		
AVS 55	380/3/50	4,10			12,30	16,40	20,50	24,60	28,70	32,80			18,7	28,5	37,4	37,4	47,0	56,1			25	40	50	50	60	80	80
AVS 65	380/3/50	4,10			12,30	16,40	20,50	24,60	28,70	32,80			18,7	28,5	37,4	37,4	47,0	56,1			25	40	50	50	60	80	80
AVS 85	380/3/50	4,10				16,40	20,50	24,60	28,70	32,80				28,5	37,4	37,4	47,0	56,1				40	50	50	60	80	80
AVS 100	380/3/50	4,10						24,60	28,70	32,80						37,4	47,0	56,1					50	60	80	80	
AVS 130	380/3/50	4,10						24,60	28,70	32,80						37,4	47,0	56,1					50	60	80	80	
AVS 170	380/3/50	4,10																									
AVS 230	380/3/50	4,10																									
AVS 300	380/3/50	4,10																									
AVS 380	380/3/50	4,10																									

Table 16 Electric Heaters 3x380 [V] (50 and 60 Hz) with heater element number 8-16

Unit type&size	Voltage	P(N1) [kW]	Pn Total nominal power of the heater at desired power supply voltage													FLA Full load amperes													MCB Max Circuit Breaker					
			P(N8) [kW]	P(N9) [kW]	P(N10) [kW]	P(N11) [kW]	P(N12) [kW]	P(N13) [kW]	P(N14) [kW]	P(N15) [kW]	P(N16) [kW]	I(N8) [A]	I(N9) [A]	I(N10) [A]	I(N11) [A]	I(N12) [A]	I(N13) [A]	I(N14) [A]	I(N15) [A]	I(N16) [A]	I(N8) [A]	I(N9) [A]	I(N10) [A]	I(N11) [A]	I(N12) [A]	I(N13) [A]	I(N14) [A]	I(N15) [A]	I(N16) [A]					
			8	9	10	11	12	13	14	15	16	8	9	10	11	12	13	14	15	16	8	9	10	11	12	13	14	15	16					
AVS 8	380/3/50	2,05																																
AVS 12	380/3/50	2,05																																
AVS 16	380/3/50	2,05																																
AVS 20	380/3/50	2,05																																
AVS 30	380/3/50	2,05	16,4	18,5	20,5															28,0	28,0	32,8												
AVS 40	380/3/50	4,10																																
AVS 55	380/3/50	4,10	32,8	36,9	41,0	45,1	49,2													56,1	56,1	65,6												
AVS 65	380/3/50	4,10	32,8	36,9	41,0	45,1	49,2													56,1	56,1	65,6	74,8	74,8										
AVS 85	380/3/50	4,10	32,8	36,9	41,0	45,1	49,2													56,1	56,1	65,6	74,8	74,8										
AVS 100	380/3/50	4,10	32,8	36,9	41,0	45,1	49,2	53,3	57,4	61,5	65,6									56,1	56,1	65,6	74,8	74,8	84,3	93,4	93,4	102,9						
AVS 130	380/3/50	4,10	32,8	36,9	41,0	45,1	49,2	53,3	57,4	61,5	65,6									56,1	56,1	65,6	74,8	74,8	84,3	93,4	93,4	102,9	80	80				
AVS 170	380/3/50	4,10		36,9	41,0	45,1	49,2	53,3	57,4	61,5	65,6									56,1	56,1	65,6	74,8	74,8	84,3	93,4	93,4	102,9	80	80				
AVS 230	380/3/50	4,10		36,9	41,0	45,1	49,2	53,3	57,4	61,5	65,6									56,1	56,1	65,6	74,8	74,8	84,3	93,4	93,4	102,9	80	80				
AVS 300	380/3/50	4,10					49,2	53,3	57,4	61,5	65,6									56,1	56,1	65,6	74,8	74,8	84,3	93,4	93,4	102,9	80	80				
AVS 380	380/3/50	4,10																																

Table 17 Electric Heaters 3x380 [V] (50 and 60 Hz) with heater element number 17-36

Unit type&size	Voltage	P(N1) [kW]	Pn Total nominal power of the heater at desired power supply voltage						FLA Full load amperes						MCB Max Circuit Breaker												
			P(N17) [kW]	P(N18) [kW]	P(N21) [kW]	P(N24) [kW]	P(N27) [kW]	P(N30) [kW]	P(N33) [kW]	P(N36) [kW]	I(N17) [A]	I(N18) [A]	I(N21) [A]	I(N24) [A]	I(N27) [A]	I(N30) [A]	I(N33) [A]	I(N36) [A]	I(N17) [A]	I(N18) [A]	I(N21) [A]	I(N24) [A]	I(N27) [A]	I(N30) [A]	I(N33) [A]	I(N36) [A]	
			17	18	21	24	27	30	33	36	17	18	21	24	27	30	33	36	17	18	21	24	27	30	33	36	
AVS 8	380/3/50	2,05																									
AVS 12	380/3/50	2,05																									
AVS 16	380/3/50	2,05																									
AVS 20	380/3/50	2,05																									
AVS 30	380/3/50	2,05																									
AVS 40	380/3/50	4,10																									
AVS 55	380/3/50	4,10																									
AVS 65	380/3/50	4,10																									
AVS 85	380/3/50	4,10																									
AVS 100	380/3/50	4,10	69,7	73,8																							
AVS 130	380/3/50	4,10	69,7	73,8																							
AVS 170	380/3/50	4,10	69,7	73,8																							
AVS 230	380/3/50	4,10	69,7	73,8																							
AVS 300	380/3/50	4,10	69,7	73,8	86,1	98,4	110,7	123,0	135,3	147,6																	
AVS 380	380/3/50	4,10		73,8	86,1	98,4	110,7	123,0	135,3	147,6																	

Table 18 Electric Heaters 3x460 [V] (60Hz) with heater element number 1-8

Unit type&size	Voltage	P(N1) [kW]	Pn Total nominal power of the heater at desired power supply voltage								FLA Full load amperes								MCB Max Circuit Breaker							
			P(N1) [kW]	P(N2) [kW]	P(N3) [kW]	P(N4) [kW]	P(N5) [kW]	P(N6) [kW]	P(N7) [kW]	P(N8) [kW]	I(N1) [A]	I(N2) [A]	I(N3) [A]	I(N4) [A]	I(N5) [A]	I(N6) [A]	I(N7) [A]	I(N8) [A]	I(N1) [A]	I(N2) [A]	I(N3) [A]	I(N4) [A]	I(N5) [A]	I(N6) [A]	I(N7) [A]	I(N8) [A]
			1	2	3	4	5	6	7	8	1	2	3	4	5	6	7	8	1	2	3	4	5	6	7	8
AVS 8	460/3/60	3,00	3	6	9						6,5	11,3	11,3					15	15	15						
AVS 12	460/3/60	3,00	3	6	9	12					6,5	11,3	11,3	17,3				15	15	15	25					
AVS 16	460/3/60	3,00	3	6	9	12	15				6,5	11,3	11,3	17,3	22,6			15	15	15	25	30				
AVS 20	460/3/60	3,00		6	9	12	15	18				11,3	11,3	17,3	22,6	22,6			15	15	15	25	30	30	40	
AVS 30	460/3/60	3,00		6	9	12	15	18		21		11,3	11,3	17,3	22,6	22,6			15	15	15	25	30	40	45	
AVS 40	460/3/60	6,00		12	18	24	30	36				22,6	22,6	34,5	45,2				30	30	45	60	60			
AVS 55	460/3/60	6,00			18	24	30	36	42	48			22,6	34,5	45,2	45,2	56,9			30	45	60	60	80	90	
AVS 65	460/3/60	6,00			18	24	30	36	42	48			22,6	34,5	45,2	45,2	56,9			30	45	60	60	80	90	
AVS 85	460/3/60	6,00				24	30	36	42	48				34,5	45,2	45,2	56,9				45	60	60	80	90	
AVS 100	460/3/60	6,00						36	42	48					45,2	56,9	67,8						60	80	90	
AVS 130	460/3/60	6,00							36	42	48					56,9	67,8						60	80	90	
AVS 170	460/3/60	6,00																								
AVS 230	460/3/60	6,00																								
AVS 300	460/3/60	6,00																								
AVS 380	460/3/60	6,00																								

Table 19 Electric Heaters 3x460 [V] (60Hz) with heater element number 9-16

Unit type&size	Voltage	P(N1)	Pn								FLA								MCB							
			Total nominal power of the heater at desired power supply voltage								Full load amperes								Max Circuit Breaker							
			P(N9) [kW]	P(N10) [kW]	P(N11) [kW]	P(N12) [kW]	P(N13) [kW]	P(N14) [kW]	P(N15) [kW]	P(N16) [kW]	I(N9) [A]	I(N10) [A]	I(N11) [A]	I(N12) [A]	I(N13) [A]	I(N14) [A]	I(N15) [A]	I(N16) [A]	I(N9) [A]	I(N10) [A]	I(N11) [A]	I(N12) [A]	I(N13) [A]	I(N14) [A]	I(N15) [A]	I(N16) [A]
	[V/f/Hz]	[kW]	9	10	11	12	13	14	15	16	9	10	11	12	13	14	15	16	9	10	11	12	13	14	15	16
AVS 8	460/3/60	3,00																								
AVS 12	460/3/60	3,00																								
AVS 16	460/3/60	3,00																								
AVS 20	460/3/60	3,00																								
AVS 30	460/3/60	3,00	27	30							33,9	39,7							45	50						
AVS 40	460/3/60	6,00																								
AVS 55	460/3/60	6,00	54	60	66	72					67,8	79,3	90,4	90,4					90	100	125	125				
AVS 65	460/3/60	6,00	54	60	66	72					67,8	79,3	90,4	90,4					90	100	125	125				
AVS 85	460/3/60	6,00	54	60	66	72					67,8	79,3	90,4	90,4					90	100	125	125				
AVS 100	460/3/60	6,00	54	60	66	72	78	84	90	96	67,8	79,3	90,4	90,4	101,9	113,0	113,0	124,4	90	100	125	125	150	150	150	175
AVS 130	460/3/60	6,00	54	60	66	72	78	84	90	96	67,8	79,3	90,4	90,4	101,9	113,0	113,0	124,4	90	100	125	125	150	150	150	175
AVS 170	460/3/60	6,00	54	60	66	72	78	84	90	96	67,8	79,3	90,4	90,4	101,9	113,0	113,0	124,4	90	100	125	125	150	150	150	175
AVS 230	460/3/60	6,00	54	60	66	72	78	84	90	96	67,8	79,3	90,4	90,4	101,9	113,0	113,0	124,4	90	100	125	125	150	150	150	175
AVS 300	460/3/60	6,00				72	78	84	90	96				90,4	101,9	113,0	113,0	124,4				125	150	150	150	175
AVS 380	460/3/60	6,00																								

Table 20 Electric Heaters 3x460 [V] (60Hz) with heater element number 17-36

Unit type&size	Voltage	P(N1)	Pn								FLA								MCB							
			Total nominal power of the heater at desired power supply voltage								Full load amperes								Max Circuit Breaker							
			P(N17) [kW]	P(N18) [kW]	P(N21) [kW]	P(N24) [kW]	P(N27) [kW]	P(N30) [kW]	P(N33) [kW]	P(N36) [kW]	I(N17) [A]	I(N18) [A]	I(N21) [A]	I(N24) [A]	I(N27) [A]	I(N30) [A]	I(N33) [A]	I(N36) [A]	I(N17) [A]	I(N18) [A]	I(N21) [A]	I(N24) [A]	I(N27) [A]	I(N30) [A]	I(N33) [A]	I(N36) [A]
	[V/f/Hz]	[kW]	17	18	21	24	27	30	33	36	17	18	21	24	27	30	33	36	17	18	21	24	27	30	33	36
AVS 8	460/3/60	3,00																								
AVS 12	460/3/60	3,00																								
AVS 16	460/3/60	3,00																								
AVS 20	460/3/60	3,00																								
AVS 30	460/3/60	3,00																								
AVS 40	460/3/60	6,00																								
AVS 55	460/3/60	6,00																								
AVS 65	460/3/60	6,00																								
AVS 85	460/3/60	6,00																								
AVS 100	460/3/60	6,00	102	108							135,6	135,6							175	175						
AVS 130	460/3/60	6,00	102	108							135,6	135,6							175	175						
AVS 170	460/3/60	6,00	102	108							135,6	135,6							175	175						
AVS 230	460/3/60	6,00	102	108							135,6	135,6							175	175						
AVS 300	460/3/60	6,00	102	108	126	144	162	180	198	216	135,6	135,6	158,1	180,7	203,3	225,9	248,5	271,1	175	175	200	250	300	300	350	350
AVS 380	460/3/60	6,00		108	126	144	162	180	198	216		135,6	158,1	180,7	203,3	225,9	248,5	271,1		175	200	250	300	300	350	350

Table 21 Electric Heaters for AHU from AVS8 to AVS100 – Tutco

AVS HEATER P/N	AVS UNIT Model	Unit Internal Dimensions		kW	Voltage	PHASE	AMPS	ALT. VOLTAGE	ALT. VOLTAGE KW	ALT. VOLTAGE AMPS	SUB-CIRCUIT QTY.	Height	Width	"B/D" Dim	Z Dim	Q Dim
		H (")	W (")													
AVS 8 HE 9kW 3~240V	AVS8	14.5	24	6.2	240	3	14.9	208	4.65	12.91	1	12.0	14.5	8.0	14.0	14.4
AVS 8 HE 9kW 3~380V	AVS8	14.5	24	6.2	380	3	9.4	N/A	N/A	N/A	1	12.0	14.5	8.0	14.0	14.4
AVS 8 HE 9kW 3~480V	AVS8	14.5	24	6.2	480	3	7.5	N/A	N/A	N/A	1	12.0	14.5	8.0	14.0	14.4
AVS 8 HE 9kW 3~600V	AVS8	14.5	24	6.2	600	3	6.0	N/A	N/A	N/A	1	12.0	14.5	8.0	14.0	14.4
AVS 12 HE 12kW 3~240V	AVS12	14.5	34.6	9.4	240	3	22.6	208	7.05	19.57	1	12.0	25.0	8.0	14.0	14.4
AVS 12 HE 12kW 3~380V	AVS12	14.5	34.6	9.4	380	3	14.3	N/A	N/A	N/A	1	12.0	25.0	8.0	14.0	14.4
AVS 12 HE 12kW 3~480V	AVS12	14.5	34.6	9.4	480	3	11.3	N/A	N/A	N/A	1	12.0	25.0	8.0	14.0	14.4
AVS 12 HE 12kW 3~600V	AVS12	14.5	34.6	9.4	600	3	9.1	N/A	N/A	N/A	1	12.0	25.0	8.0	14.0	14.4
AVS 16 HE 15kW 3~240V	AVS16	16.5	40.2	12	240	3	28.9	208	9	24.98	1	14.0	30.6	8.0	16.0	14.4
AVS 16 HE 15kW 3~380V	AVS16	16.5	40.2	12	380	3	18.2	N/A	N/A	N/A	1	14.0	30.6	8.0	16.0	14.4
AVS 16 HE 15kW 3~480V	AVS16	16.5	40.2	12	480	3	14.4	N/A	N/A	N/A	1	14.0	30.6	8.0	16.0	14.4
AVS 16 HE 15kW 3~600V	AVS16	16.5	40.2	12	600	3	11.6	N/A	N/A	N/A	1	14.0	30.6	8.0	16.0	14.4
AVS 20 HE 21kW 3~240V	AVS20	19.7	42.8	16	240	3	38.5	208	12	33.31	2	17.2	33.3	8.0	19.2	14.4
AVS 20 HE 21kW 3~380V	AVS20	19.7	42.8	16	380	3	24.3	N/A	N/A	N/A	1	17.2	33.3	8.0	19.2	14.4
AVS 20 HE 21kW 3~480V	AVS20	19.7	42.8	16	480	3	19.3	N/A	N/A	N/A	1	17.2	33.3	8.0	19.2	14.4
AVS 20 HE 21kW 3~600V	AVS20	19.7	42.8	16	600	3	15.4	N/A	N/A	N/A	1	17.2	33.3	8.0	19.2	14.4
AVS 30 HE 30kW 3~240V	AVS30	25	49.5	23	240	3	55.3	208	17.25	47.88	2	22.5	40.0	8.0	24.5	14.4
AVS 30 HE 30kW 3~380V	AVS30	25	49.5	23	380	3	35.0	N/A	N/A	N/A	1	22.5	40.0	8.0	24.5	14.4
AVS 30 HE 30kW 3~480V	AVS30	25	49.5	23	480	3	27.7	N/A	N/A	N/A	1	22.5	40.0	8.0	24.5	14.4
AVS 30 HE 30kW 3~600V	AVS30	25	49.5	23	600	3	22.1	N/A	N/A	N/A	1	22.5	40.0	8.0	24.5	14.4
AVS 40 HE 36kW 3~240V	AVS-40	29.7	55.1	31	240	3	74.6	208	23.25	64.54	2	27.2	45.5	8.0	29.2	14.4
AVS 40 HE 36kW 3~380V	AVS-40	29.7	55.1	31	380	3	47.1	N/A	N/A	N/A	2	27.2	45.5	8.0	29.2	14.4
AVS 40 HE 36kW 3~480V	AVS-40	29.7	55.1	31	480	3	37.3	N/A	N/A	N/A	1	27.2	45.5	8.0	29.2	14.4
AVS 40 HE 36kW 3~600V	AVS-40	29.7	55.1	31	600	3	29.8	N/A	N/A	N/A	1	27.2	45.5	8.0	29.2	14.4
AVS 55 HE 36kW 3~240V	AVS-55	33.7	62.2	36	240	3	86.6	208	27	74.95	2	31.2	52.6	8.0	33.2	14.4
AVS 55 HE 36kW 3~380V	AVS-55	33.7	62.2	36	380	3	54.7	N/A	N/A	N/A	2	31.2	52.6	8.0	33.2	14.4
AVS 55 HE 36kW 3~480V	AVS-55	33.7	62.2	36	480	3	43.3	N/A	N/A	N/A	1	31.2	52.6	8.0	33.2	14.4
AVS 55 HE 36kW 3~600V	AVS-55	33.7	62.2	36	600	3	34.6	N/A	N/A	N/A	1	31.2	52.6	8.0	33.2	14.4
AVS 55 HE 72kW 3~380V	AVS-55	33.7	62.2	43	380	3	65.3	N/A	N/A	N/A	2	31.2	52.6	8.0	33.2	26.0
AVS 55 HE 72kW 3~480V	AVS-55	33.7	62.2	43	480	3	51.7	N/A	N/A	N/A	2	31.2	52.6	8.0	33.2	14.4
AVS 55 HE 72kW 3~600V	AVS-55	33.7	62.2	43	600	3	41.4	N/A	N/A	N/A	2	31.2	52.6	8.0	33.2	14.4
AVS 65 HE 36kW 3~240V	AVS-65	35.1	71.3	36	240	3	86.6	208	27	74.95	2	32.5	61.8	8.0	34.5	14.4
AVS 65 HE 36kW 3~380V	AVS-65	35.1	71.3	36	380	3	54.7	N/A	N/A	N/A	2	32.5	61.8	8.0	34.5	14.4
AVS 65 HE 36kW 3~480V	AVS-65	35.1	71.3	36	480	3	43.3	N/A	N/A	N/A	1	32.5	61.8	8.0	34.5	14.4
AVS 65 HE 36kW 3~600V	AVS-65	35.1	71.3	36	600	3	34.6	N/A	N/A	N/A	1	32.5	61.8	8.0	34.5	14.4
AVS 65 HE 72kW 3~380V	AVS-65	35.1	71.3	51	380	3	77.5	N/A	N/A	N/A	2	32.5	61.8	8.0	34.5	26.0
AVS 65 HE 72kW 3~480V	AVS-65	35.1	71.3	51	480	3	61.4	N/A	N/A	N/A	2	32.5	61.8	8.0	34.5	14.4
AVS 65 HE 72kW 3~600V	AVS-65	35.1	71.3	51	600	3	49.1	N/A	N/A	N/A	2	32.5	61.8	8.0	34.5	14.4
AVS 85 HE 36kW 3~240V	AVS-85	39.1	78.9	36	240	3	86.6	208	27	74.95	2	36.5	69.4	8.0	38.5	14.4
AVS 85 HE 36kW 3~380V	AVS-85	39.1	78.9	36	380	3	54.7	N/A	N/A	N/A	2	36.5	69.4	8.0	38.5	14.4
AVS 85 HE 36kW 3~480V	AVS-85	39.1	78.9	36	480	3	43.3	N/A	N/A	N/A	1	36.5	69.4	8.0	38.5	14.4
AVS 85 HE 36kW 3~600V	AVS-85	39.1	78.9	36	600	3	34.6	N/A	N/A	N/A	1	36.5	69.4	8.0	38.5	14.4
AVS 85 HE 72kW 3~380V	AVS-85	39.1	78.9	66	380	3	100.3	N/A	N/A	N/A	2	36.5	69.4	8.0	38.5	26.0
AVS 85 HE 72kW 3~480V	AVS-85	39.1	78.9	66	480	3	79.4	N/A	N/A	N/A	2	36.5	69.4	8.0	38.5	14.4
AVS 85 HE 72kW 3~600V	AVS-85	39.1	78.9	66	600	3	63.5	N/A	N/A	N/A	2	36.5	69.4	8.0	38.5	14.4
AVS 100 HE 36kW 3~240V	AVS-100	47.1	78.9	36	240	3	86.6	208	27	74.95	2	44.5	69.4	8.0	46.5	14.4
AVS 100 HE 36kW 3~380V	AVS-100	47.1	78.9	36	380	3	54.7	N/A	N/A	N/A	2	44.5	69.4	8.0	46.5	14.4
AVS 100 HE 36kW 3~480V	AVS-100	47.1	78.9	36	480	3	43.3	N/A	N/A	N/A	1	44.5	69.4	8.0	46.5	14.4
AVS 100 HE 36kW 3~600V	AVS-100	47.1	78.9	36	600	3	34.6	N/A	N/A	N/A	1	44.5	69.4	8.0	46.5	14.4
AVS 100 HE 72kW 3~380V	AVS-100	47.1	78.9	78	380	3	118.5	N/A	N/A	N/A	3	44.5	69.4	8.0	46.5	26.0
AVS 100 HE 72kW 3~480V	AVS-100	47.1	78.9	78	480	3	93.8	N/A	N/A	N/A	2	44.5	69.4	8.0	46.5	14.4
AVS 100 HE 72kW 3~600V	AVS-100	47.1	78.9	78	600	3	75.1	N/A	N/A	N/A	2	44.5	69.4	8.0	46.5	14.4

Table 22 Electric Heaters for AHU from AVS130 to AVS380 – Tutco

AVS HEATER P/N	AVS UNIT Model	Unit Internal Dimensions		Power kW	Voltage	PHASE	AMPS	ALT. VOLTAGE	ALT. VOLTAGE	ALT. VOLTAGE AMPS	SUB-CIRCUIT QTY.	Height	Width	"B/D" Dim	Z Dim	Q Dim
		H (")	W (")													
AVS130 HE 36kW 3~240V	AVS-130	47.1	95	36	240	3	86.6	208	27	74.95	2	44.5	85.5	8.0	46.5	14.4
AVS130 HE 36kW 3~380V	AVS-130	47.1	95	36	380	3	54.7	N/A	N/A	N/A	2	44.5	85.5	8.0	46.5	14.4
AVS130 HE 36kW 3~480V	AVS-130	47.1	95	36	480	3	43.3	N/A	N/A	N/A	1	44.5	85.5	8.0	46.5	14.4
AVS130 HE 36kW 3~600V	AVS-130	47.1	95	36	600	3	34.6	N/A	N/A	N/A	1	44.5	85.5	8.0	46.5	14.4
AVS130 HE 108kW 3~380V	AVS-130	47.1	95	102	380	3	155.0	N/A	N/A	N/A	4	44.5	85.5	8.0	46.5	26.0
AVS130 HE 108kW 3~480V	AVS-130	47.1	95	102	480	3	122.7	N/A	N/A	N/A	3	44.5	85.5	8.0	46.5	26.0
AVS130 HE 108kW 3~600V	AVS-130	47.1	95	102	600	3	98.2	N/A	N/A	N/A	3	44.5	85.5	8.0	46.5	26.0
AVS170 HE 36kW 3~240V	AVS-170	58.9	98.6	36	240	3	86.6	208	27	74.95	2	56.4	87.5	9.5	58.4	14.4
AVS170 HE 36kW 3~380V	AVS-170	58.9	98.6	36	380	3	54.7	N/A	N/A	N/A	2	56.4	87.5	9.5	58.4	14.4
AVS170 HE 36kW 3~480V	AVS-170	58.9	98.6	36	480	3	43.3	N/A	N/A	N/A	1	56.4	87.5	9.5	58.4	14.4
AVS170 HE 36kW 3~600V	AVS-170	58.9	98.6	36	600	3	34.6	N/A	N/A	N/A	1	56.4	87.5	9.5	58.4	14.4
AVS170 HE 72kW 3~380V	AVS-170	58.9	98.6	72	380	3	109.4	N/A	N/A	N/A	3	56.4	87.5	9.5	58.4	26.0
AVS170 HE 72kW 3~480V	AVS-170	58.9	98.6	72	480	3	86.6	N/A	N/A	N/A	2	56.4	87.5	9.5	58.4	14.4
AVS170 HE 72kW 3~600V	AVS-170	58.9	98.6	72	600	3	69.3	N/A	N/A	N/A	2	56.4	87.5	9.5	58.4	14.4
AVS170 HE 108kW 3~380V	AVS-170	58.9	98.6	133	380	3	202.1	N/A	N/A	N/A	4	56.4	87.5	9.5	58.4	26.0
AVS170 HE 108kW 3~480V	AVS-170	58.9	98.6	133	480	3	160.0	N/A	N/A	N/A	3	56.4	87.5	9.5	58.4	26.0
AVS170 HE 108kW 3~600V	AVS-170	58.9	98.6	133	600	3	128.0	N/A	N/A	N/A	3	56.4	87.5	9.5	58.4	26.0
AVS230 HE 36kW 3~240V	AVS-230	68.1	118.3	36	240	3	86.6	208	27	74.95	2	65.5	107.3	9.5	67.5	14.4
AVS230 HE 36kW 3~380V	AVS-230	68.1	118.3	36	380	3	54.7	N/A	N/A	N/A	2	65.5	107.3	9.5	67.5	14.4
AVS230 HE 36kW 3~480V	AVS-230	68.1	118.3	36	480	3	43.3	N/A	N/A	N/A	1	65.5	107.3	9.5	67.5	14.4
AVS230 HE 36kW 3~600V	AVS-230	68.1	118.3	36	600	3	34.6	N/A	N/A	N/A	1	65.5	107.3	9.5	67.5	14.4
AVS230 HE 72kW 3~380V	AVS-230	68.1	118.3	72	380	3	109.4	N/A	N/A	N/A	3	65.5	107.3	9.5	67.5	26.0
AVS230 HE 72kW 3~480V	AVS-230	68.1	118.3	72	480	3	86.6	N/A	N/A	N/A	2	65.5	107.3	9.5	67.5	14.4
AVS230 HE 72kW 3~600V	AVS-230	68.1	118.3	72	600	3	69.3	N/A	N/A	N/A	2	65.5	107.3	9.5	67.5	14.4
AVS230 HE 108kW 3~380V	AVS-230	68.1	118.3	108	380	3	164.1	N/A	N/A	N/A	4	65.5	107.3	9.5	67.5	26.0
AVS230 HE 108kW 3~480V	AVS-230	68.1	118.3	108	480	3	129.9	N/A	N/A	N/A	3	65.5	107.3	9.5	67.5	26.0
AVS230 HE 108kW 3~600V	AVS-230	68.1	118.3	108	600	3	103.9	N/A	N/A	N/A	3	65.5	107.3	9.5	67.5	26.0
AVS230 HE 230kW 3~380V	AVS-230	68.1	118.3	188	380	3	285.6	N/A	N/A	N/A	8	65.5	107.3	9.5	67.5	26.0
AVS230 HE 230kW 3~480V	AVS-230	68.1	118.3	188	480	3	226.1	N/A	N/A	N/A	6	65.5	107.3	9.5	67.5	26.0
AVS230 HE 230kW 3~600V	AVS-230	68.1	118.3	188	600	3	180.9	N/A	N/A	N/A	5	65.5	107.3	9.5	67.5	26.0
AVS300 HE 72kW 3~380V	AVS-300	68.1	138	72	380	3	109.4	N/A	N/A	N/A	3	65.5	127.0	9.5	67.5	26.0
AVS 300 HE 72kW 3~480V	AVS-300	68.1	138	72	480	3	86.6	N/A	N/A	N/A	2	65.5	127.0	9.5	67.5	14.4
AVS 300 HE 72kW 3~600V	AVS-300	68.1	138	72	600	3	69.3	N/A	N/A	N/A	2	65.5	127.0	9.5	67.5	14.4
AVS 300 HE 108kW 3~380V	AVS-300	68.1	138	108	380	3	164.1	N/A	N/A	N/A	4	65.5	127.0	9.5	67.5	26.0
AVS 300 HE 108kW 3~480V	AVS-300	68.1	138	108	480	3	129.9	N/A	N/A	N/A	3	65.5	127.0	9.5	67.5	26.0
AVS 300 HE 108kW 3~600V	AVS-300	68.1	138	108	600	3	103.9	N/A	N/A	N/A	3	65.5	127.0	9.5	67.5	26.0
AVS 300 HE 216kW 3~380V	AVS-300	68.1	138	189	380	3	287.9	N/A	N/A	N/A	6	65.5	127.0	9.5	67.5	26.0
AVS 300 HE 216kW 3~480V	AVS-300	68.1	138	216	480	3	259.8	N/A	N/A	N/A	6	65.5	127.0	9.5	67.5	26.0
AVS 300 HE 216kW 3~600V	AVS-300	68.1	138	216	600	3	207.9	N/A	N/A	N/A	5	65.5	127.0	9.5	67.5	26.0
AVS 300 HE 300kW 3~380V	AVS-300	68.1	138	234	380	3	355.5	N/A	N/A	N/A	8	65.5	127.0	9.5	67.5	26.0
AVS 300 HE 300kW 3~480V	AVS-300	68.1	138	234	480	3	281.5	N/A	N/A	N/A	8	65.5	127.0	9.5	67.5	26.0
AVS 300 HE 300kW 3~600V	AVS-300	68.1	138	234	600	3	225.2	N/A	N/A	N/A	6	65.5	127.0	9.5	67.5	26.0
AVS 380 HE 72kW 3~380V	AVS-380	86.9	142.4	72	380	3	109.4	N/A	N/A	N/A	3	84.4	131.4	9.5	86.4	26.0
AVS 380 HE 72kW 3~480V	AVS-380	86.9	142.4	72	480	3	86.6	N/A	N/A	N/A	2	84.4	131.4	9.5	86.4	14.4
AVS 380 HE 72kW 3~600V	AVS-380	86.9	142.4	72	600	3	69.3	N/A	N/A	N/A	2	84.4	131.4	9.5	86.4	14.4
AVS 380 HE 108kW 3~380V	AVS-380	86.9	142.4	108	380	3	164.1	N/A	N/A	N/A	4	84.4	131.4	9.5	86.4	26.0
AVS 380 HE 108kW 3~480V	AVS-380	86.9	142.4	108	480	3	129.9	N/A	N/A	N/A	3	84.4	131.4	9.5	86.4	26.0
AVS 380 HE 108kW 3~600V	AVS-380	86.9	142.4	108	600	3	103.9	N/A	N/A	N/A	3	84.4	131.4	9.5	86.4	26.0
AVS 380 HE 216kW 3~380V	AVS-380	86.9	142.4	190	380	3	287.9	N/A	N/A	N/A	6	84.4	131.4	9.5	86.4	26.0
AVS 380 HE 216kW 3~480V	AVS-380	86.9	142.4	216	480	3	259.8	N/A	N/A	N/A	6	84.4	131.4	9.5	86.4	26.0
AVS 380 HE 216kW 3~600V	AVS-380	86.9	142.4	216	600	3	207.9	N/A	N/A	N/A	5	84.4	131.4	9.5	86.4	26.0
AVS 380 HE 380kW 3~380V	AVS-380	86.9	142.4	253	380	3	383.7	N/A	N/A	N/A	8	84.4	131.4	9.5	86.4	26.0
AVS 380 HE 380kW 3~480V	AVS-380	86.9	142.4	297	480	3	357.3	N/A	N/A	N/A	8	84.4	131.4	9.5	86.4	26.0
AVS 380 HE 380kW 3~600V	AVS-380	86.9	142.4	297	600	3	285.8	N/A	N/A	N/A	8	84.4	131.4	9.5	86.4	26.0

7.5.2 Electric motor with frequency converter.

Use data that is given below to select relevant wires and to select relevant size of fuses. The data is presented also in the motors and AHU's nameplate.

Table 23 Full Load Amps and Maximum Circuit Breaker (1x208V)

Motor			FC Input		MAX.CKT. BKR	FC Output (el. motor input)	
Type	Casing	FLA	Phase	Un		Phase	Uo
		A		V	A		V
EL.MTR 56-1HP/2p	TEFC	3	1	208	15	3	208
EL.MTR 143T-1HP/4p	TEFC	3,1	1	208	15	3	208
EL.MTR 145T-1.5HP/4p	TEFC	4,5	1	208	15	3	208
EL.MTR 145T-2HP/2p	TEFC	5,3	1	208	15	3	208
EL.MTR 145T-2HP/4p	TEFC	6,6	1	208	15	3	208
EL.MTR 182T-3HP/4p	TEFC	9	1	208	20	3	208

Table 24 Full Load Amps and Maximum Circuit Breaker (1x230V)

Motor			FC Input		MAX.CKT. BKR	FC Output (el. motor input)	
Type	Casing	FLA	Phase	Un		Phase	Uo
		A		V	A		V
EL.MTR 56-1HP/2p	TEFC	2,8	1	230	15	3	230
EL.MTR 143T-1HP/4p	TEFC	3	1	230	15	3	230
EL.MTR 145T-1.5HP/4p	TEFC	4,4	1	230	15	3	230
EL.MTR 145T-2HP/2p	TEFC	5	1	230	15	3	230
EL.MTR 145T-2HP/4p	TEFC	5,8	1	230	15	3	230
EL.MTR 182T-3HP/4p	TEFC	8,4	1	230	20	3	230

Table 25 Full Load Amps and Maximum Circuit Breaker (3x208V)

Motor			FC Input		MAX.CKT. BKR	FC Output (el. motor input)	
Type	Casing	FLA	Phase	Un		Phase	Uo
		A		V	A		V
EL.MTR 56-1HP/2p	TEFC	3	3	208	15	3	208
EL.MTR 143T-1HP/4p	TEFC	3,1	3	208	15	3	208
EL.MTR 145T-1.5HP/4p	TEFC	4,5	3	208	15	3	208
EL.MTR 145T-2HP/2p	TEFC	5,3	3	208	15	3	208
EL.MTR 145T-2HP/4p	TEFC	6,6	3	208	15	3	208
EL.MTR 182T-3HP/4p	TEFC	9	3	208	15	3	208
EL.MTR 184T-5HP/4p	TEFC	13,9	3	208	20	3	208
EL.MTR 213T-7.5HP/4p	TEFC	21	3	208	25	3	208
EL.MTR 215T-10HP/4p	TEFC	25,4	3	208	30	3	208
EL.MTR 254T-15HP/4p	TEFC	38	3	208	45	3	208

Table 26 Full Load Amps and Maximum Circuit Breaker (3x230V)

Motor			FC Input		MAX.CKT. BKR	FC Output (el. motor input)	
Type	Casing	FLA	Phase	Un		Phase	Uo
		A		V	A		V
EL.MTR 56-1HP/2p	TEFC	2,8	3	230	15	3	230
EL.MTR 143T-1HP/4p	TEFC	3	3	230	15	3	230
EL.MTR 145T-1.5HP/4p	TEFC	4,4	3	230	15	3	230
EL.MTR 145T-2HP/2p	TEFC	5	3	230	15	3	230
EL.MTR 145T-2HP/4p	TEFC	5,8	3	230	15	3	230
EL.MTR 182T-3HP/4p	TEFC	8,4	3	230	15	3	230
EL.MTR 184T-5HP/4p	TEFC	13,4	3	230	20	3	230
EL.MTR 213T-7.5HP/4p	TEFC	18,8	3	230	25	3	230
EL.MTR 215T-10HP/4p	TEFC	24,0	3	230	30	3	230
EL.MTR 254T-15HP/4p	TEFC	36,2	3	230	45	3	230

Table 27 Full Load Amps and Maximum Circuit Breaker (3x460V)

Motor			FC Input		MAX.CKT. BKR	FC Output (el. motor input)	
Type	Casing	FLA	Phase	Un		Phase	Uo
		A		V	A		V
EL.MTR 56-1HP/2p	TEFC	1,4	3	460	15	3	460
EL.MTR 143T-1HP/4p	TEFC	1,5	3	460	15	3	460
EL.MTR 145T-1.5HP/4p	TEFC	2,2	3	460	15	3	460
EL.MTR 145T-2HP/2p	TEFC	2,5	3	460	15	3	460
EL.MTR 145T-2HP/4p	TEFC	2,9	3	460	15	3	460
EL.MTR 182T-3HP/4p	TEFC	4,2	3	460	15	3	460
EL.MTR 184T-5HP/4p	TEFC	6,7	3	460	15	3	460
EL.MTR 213T-7.5HP/4p	TEFC	9,4	3	460	15	3	460
EL.MTR 215T-10HP/4p	TEFC	12,0	3	460	15	3	460
EL.MTR 254T-15HP/4p	TEFC	18,1	3	460	25	3	460

Table 28 Full Load Amps and Maximum Circuit Breaker (3x380V)

Motor			FC Input		MAX.CKT. BKR	FC Output (el. motor input)	
Type	Casing	FLA	Phase	Un		Phase	Uo
		A		V	A		V
EL.MTR 56-1HP/2p	TEFC	1,7	3	380	15	3	380
EL.MTR 143T-1HP/4p	TEFC	1,8	3	380	15	3	380
EL.MTR 145T-1.5HP/4p	TEFC	2,7	3	380	15	3	380
EL.MTR 145T-2HP/2p	TEFC	3,0	3	380	15	3	380
EL.MTR 143T-1HP/4p	TEFC	1,8	3	380	15	3	380
EL.MTR 182T-3HP/4p	TEFC	4,2	3	380	15	3	380
EL.MTR 184T-5HP/4p	TEFC	6,7	3	380	15	3	380
EL.MTR 213T-7.5HP/4p	TEFC	9,4	3	380	15	3	380
EL.MTR 215T-10HP/4p	TEFC	12,0	3	380	15	3	380
EL.MTR 254T-15HP/4p	TEFC	18,1	3	380	25	3	380

Table 29 Full Load Amps and Maximum Circuit Breaker (3x575V)

Motor			FC Input		MAX.CKT. BKR	FC Output (el. motor input)	
Type	Casing	FLA	Phase	Un		Phase	Uo
		A		V	A		V
EL.MTR 56-1HP/2p	TEFC	1,1	3	575	2,75	3	575
EL.MTR 143T-1HP/4p	TEFC	1,2	3	575	3	3	575
EL.MTR 145T-1.5HP/4p	TEFC	1,8	1	575	4,5	3	575
EL.MTR 145T-2HP/2p	TEFC	2	3	575	5	3	575
EL.MTR 145T-2HP/4p	TEFC	2,3	1	575	5,75	3	575
EL.MTR 182T-3HP/4p	TEFC	3,4	3	575	15	3	575
EL.MTR 184T-5HP/4p	TEFC	5,4	3	575	15	3	575
EL.MTR 213T-7.5HP/4p	TEFC	7,6	3	575	15	3	575
EL.MTR 215T-10HP/4p	TEFC	9,7	3	575	15	3	575
EL.MTR 254T-15HP/4p	TEFC	14,6	3	575	25	3	575

7.6 Frequency Converter Wiring

The power and grounding connections are shown in the section 8.1 **Connection the mains supply with frequency converters.**

✓ **WARNING !** Provide a disconnect device for the inverter power supply. This device must cut off the power supply whenever necessary (during maintenance for instance).

✓ **CAUTION!** The input power supply voltage must be compatible with the inverter rated voltage. Power factor correction capacitors are not needed at the inverter input (U1/L, V1/N, W1) and must not be installed at the output (U2, V2, W2).

✓ **NOTICE !** The power supply that feeds the inverter must have a grounded neutral.

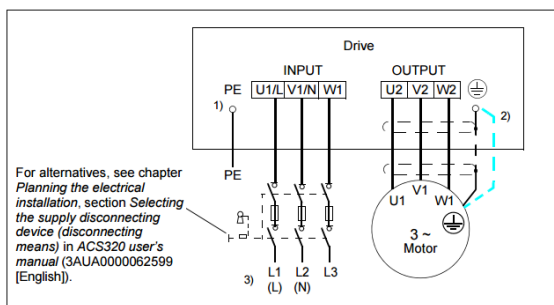

Fig. 17 Power and grounding connections

In case of IT networks, follow the instructions: In a general way, the applied inverters can be installed directly in the power supply, without reactance in the supply. However, check the following:

- In order to prevent damages to the inverter and assure the expected useful life, you must have minimum impedance that provide a voltage drop of the input power supply of 1 %. If the impedance of the input power supply (due to the transformers and cabling) is below the values listed in this table, we recommend the use of reactance in the input power supply.

- For the calculation of the input power supply reactance necessary to obtain the desired percentage voltage drop, use:

$$L = 1592 \cdot \Delta V \cdot \frac{V_e}{I_{s, rat} \cdot f} [\mu H]$$

Seeing that:

ΔV - desired input power supply drop, in percentage (%).

V_e - voltage of the phase in inverter input, in volts (V).

$I_{s, rat}$ - inverter output rated current.

f - input power supply frequency.

Control connections.

The control connections (analog input/output, digital input/output, RS485 interface and RS232 interface) must be performed according to the specification of the connector of the plug-in module connected to the frequency converter. The typical functions and connections for the standard plug-in module are shown below.

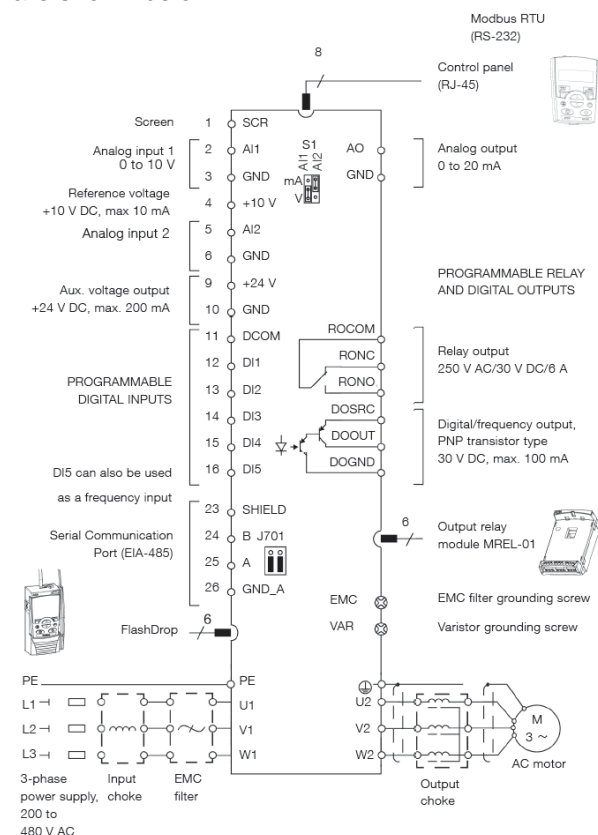

Fig. 18 Signals of the plug-in module ABB

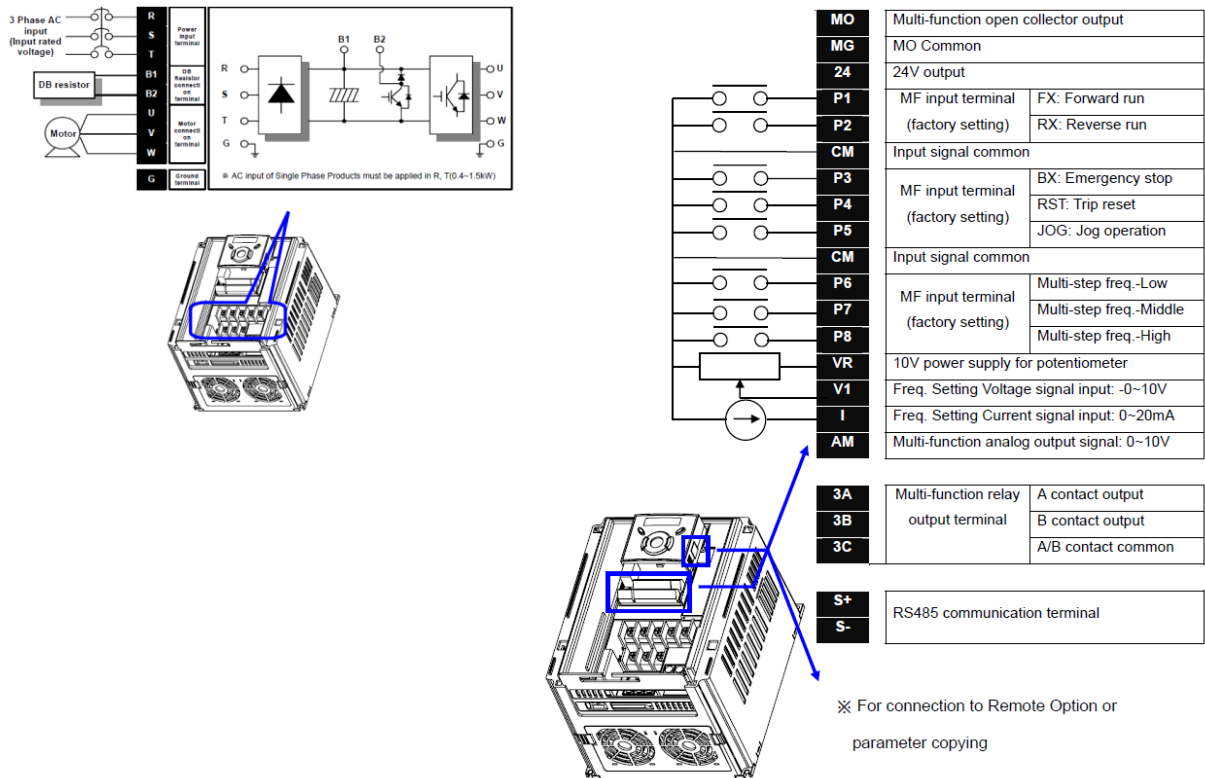

Fig. 19 Signals of the plug-in module LS

Table 30 Signals of the FC plug-in module ABB (Fig. 18)

X1A		
1	SCR	Signal cable shield (screen)
2	AI1	External reference: 0(2)...10V or 0(4)...20mA
3	GND	Analog input circuit common
4	10V	Reference voltage: 10 VDC
5	AI2	PID feedback: 0(2)...10V or 0(4)...20mA
6	GND	Analog input circuit common
7	AO	Output frequency: 0(4)...20mA
8	GND	Analog output circuit common
9	24V	Auxiliary voltage output +24 VDC
10	GND	Auxiliary voltage output common
11	DCOM	Digital input common for all
12	DI1	Start/Stop: Activate to start drive
13	DI2	Not configured
14	DI3	Constant (Preset) speed 1 (P 1202)
15	DI4	Safety interlock: Deactivate to stop drive (P 1608)
16	DI5	Not configured

Table 30 (cont.) Signals of the FC plug-in module (Fig. 18)

X1B



17	RO1C	 Relay output 1 (P 1401) Default operation: Ready => 17 connected to 19
18	RO1A	
19	RO1B	
20	DOSRC	 Digital output, max. 100 mA (P 1805) ++No fault [Fault(-1)] =>20 connected to 22
21	DOOUT	
22	DOGND	

Table 31 Signals of the FC plug-in module LS(Fig. 19)



T/M	Terminal Description	Wire size[mm ²]		Screw size	Torque [Nm]	Specification
		single wire	Stranded			
P1~P8	Multi-function input T/M 1-8	1.0	1.5	M2.6	0.4	
CM	Common Terminal	1.0	1.5	M2.6	0.4	
VR	Power supply for external potentiometer	1.0	1.5	M2.6	0.4	Output voltage: 12V Max output current: 10mA Potentiometer: 1 ~ 5kohm
V1	Input terminal for Voltage operation	1.0	1.5	M2.6	0.4	Max input voltage: -10V ~ +10V input
I	Input terminal for Current operation	1.0	1.5	M2.6	0.4	0 ~ 20mA input Internal resistor: 250 ohm
AM	Multi-function analog output terminal	1.0	1.5	M2.6	0.4	Max output voltage: 11[V] Max output current: 10mA
MO	Multi-function terminal for open collector	1.0	1.5	M2.6	0.4	Below DC 26V,100mA
MG	Ground terminal for external power supply	1.0	1.5	M2.6	0.4	
24	24V External Power Supply	1.0	1.5	M2.6	0.4	Max output current: 100mA
3A	Multi-function relay output A contact	1.0	1.5	M2.6	0.4	Below AC 250V, 1A
3B	Multi-function relay output B contact	1.0	1.5	M2.6	0.4	Below DC 30V, 1A
3C	Common for Multi-function relays	1.0	1.5	M2.6	0.4	

Table 32 ABB: Frequency converter - Specs

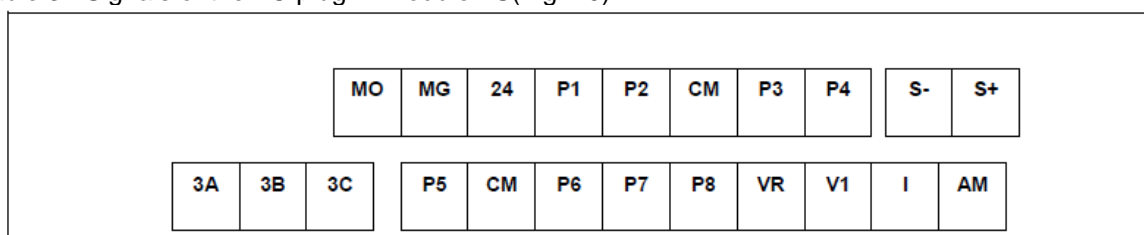
Mains Connection	
Voltage and power range	1 phase, 200 to 240V \pm 10%
	2.4 to 9.8 A (I_{2N})
	3 phase, 200 to 240V \pm 10%
	2.6 to 50.8 A (I_{2N})
	3 phase, 380 to 480V \pm 10%
	1.2 to 44.0 A (I_{2N})
Frequency	48 to 63 Hz

Motor Connection	
Voltage	3-phase, from 0 to U_{supply}
Frequency	0 to 500 Hz
Continuous loading capability	<p>I_{2N} maximum continuous output current at ambient temperature of +40 °C No overload ability, derating 1% for every additional 1 °C up to 50 °C</p> <p>I_{LD} continuous output current at max ambient temperature of +50 °C 10% overload ability for one minute every ten minutes</p>
Switching frequency	
Default	4 kHz
Selectable	4 to 16 kHz with 4 kHz steps
Acceleration time	0.1 to 1800 s
Deceleration time	0.1 to 1800 s
Motor control method	Scalar U/f

Environmental Limits	
Ambient temperature	-10 to 50 °C (14 to 122 °F), no frost allowed
Altitude	Rated current available at 0 to 1000 m (0 to 3281 ft) reduced by 1% per 100 m (328 ft) over 1000 to 2000 m (3281 to 6562 ft)
Relative humidity	Lower than 95% (without condensation)
Degree of protection	IP20/optional NEMA 1 enclosure
Enclosure color	NCS 1502-Y, RAL 9002, PMS 420 C
Contamination levels	IEC721-3-3
Transportation	<p>No conductive dust allowed</p> <p>Class 1C2 (chemical gases)</p> <p>Class 1S2 (solid particles)</p>

Storage	Class 2C2 (chemical gases)
	Class 2S2 (solid particles)
Operation	Class 3C2 (chemical gases)
	Class 3S2 (solid particles)

Table 32 (cont.) ABB: Frequency converter - Specs

Product compliance
Low Voltage Directive 2006/95/EC
Machinery Directive 2006/42/ES
EMC Directive 2004/108/EC
Quality assurance system ISO 9001
Environmental system ISO 14001
UL, cUL, CE, C-Tick and GOST R approvals
RoHS compliant

Table 32 (cont.) ABB: Frequency converter - Specs

Programmable Control Connections	
Two analog inputs	1 phase, 200 to 240V \pm 10%
Voltage signal	
Unipolar	0 (2) to 10 V, $R_{in} > 321 \text{ k}\Omega$
Bipolar	-10 to 10 V, $R_{in} > 321 \text{ k}\Omega$
Current signal	
Unipolar	0 (4) to 20 mA, $R_{in} = 100 \Omega$
Bipolar	-20 to 20 mA, $R_{in} = 100 \Omega$
Resolution	0.10%
Accuracy	$\pm 1\%$
One analog output	0 (4) to 20 mA, load $< 100 \Omega$
Auxiliary voltage	24 V DC $\pm 10\%$, max. 200 mA
Five digital inputs	12 to 24 V DC with internal or external supply, PNP and NPN, pulse train
	0 to 16 kHz
Input impedance	2.4 k Ω
One relay output	
Type	NO + NC
Maximum switching voltage	250 V AC/30 V DC
Maximum switching current	0.5 A/30 V DC; 5 A/230 V AC
Maximum continuous current	2 A rms
One digital output	
Type	Transistor output
Maximum switching voltage	30 V DC
Maximum switching current	100 mA/30 V DC, short circuit
Frequency	10 Hz to 16 kHz
Resolution	1 Hz
Accuracy	0.20%

Programmable Control Connections	
Cable	Shielded twisted pair, impedance 100 to 150 ohms

Termination	Daisy-chained bus, without dropout lines
Isolation	Bus interface isolated from drive
Transfer rate	1.2 to 76.8 kbit/s
Communication Type	Serial, asynchronous, half duplex
Protocol	Modbus TRU (EIA-485);
Protocol – cont.	Johnson Controls N2; Siemens Building Technology FLN (P1); BACnet (MS/TP)

Programmable Control Connections	
AC input chokes	External option For reducing THD in partial loads and to comply with EN/IEC 61000-3-12
AC output chokes	External option To achieve longer motor cables

Table 33 LS: Frequency converter – Specs

Mains Connection	
Voltage range	3 phase, 380 to 480V + 10% - 15%
Frequency input	50-60 [Hz] ± 5%

● Control

Control method		V/F, Sensorless vector control
Frequency setting resolution		Digital command: 0.01Hz Analog command: 0.06Hz (Max freq.: 60Hz)
Frequency accuracy		Digital command: 0.01% of Max output frequency Analog command: 0.1% of Max output frequency
V/F pattern		Linear, Squared, User V/F
Overload capacity		150% per 1 min.
Torque boost		Manual/Auto torque boost
Dynamic Braking	Max braking torque	20% ¹⁾
	Time/%ED	150% ²⁾ when using optional DB resistor

1) Means average braking torque during Decel to stop of a motor.

● Operation

Operation mode		Keypad/ Terminal/ Communication option/ Remote keypad selectable	
Frequency setting		Analog: 0 ~ 10[V], -10 ~ 10[V], 0 ~ 20[mA] Digital: Keypad	
Operation features		PID, Up-down, 3-wire	
Input	Multi-function terminal P1 ~ P8	NPN / PNP selectable (See page 2-13)	
		FWD/REV RUN, Emergency stop, Fault reset, Jog operation, Multi-step Frequency-High, Mid, Low, Multi-step Accel/Decel-High, Mid, Low, DC braking at stop, 2 nd motor select, Frequency UP/Down, 3-wire operation, External trip A, B, PID-Inverter (v/f) operation bypass, Option-inverter (v/f) operation bypass, 2 nd Source, Analog Hold, Accel/Decel stop, Up/Down Save Freq, Jog FX/RX	
Output	Open collector terminal	Fault output and inverter status output	Less than DC 24V 50mA
	Multi-function relay		(N.O., N.C.) Less than AC250V 1A, Less than DC 30V 1A
	Analog output	0 ~ 10 Vdc (less than 10mA): Output Freq, Output Current, Output Voltage, DC link selectable	

● Protective function

Trip	Over Voltage, Under Voltage, Over Current, Over Current 2, Ground Fault current detection, Inverter Overheat, Motor Overheat, Output Phase Open, Overload Protection, Communication Error, Loss of Speed Command, Hardware Fault, Fan trip, Brake error.
Alarm	Stall prevention, overload
Momentary Power Loss ¹⁾	Below 15 msec: Continuous operation (should be within rated input voltage, rated output power.) Above 15 msec: Auto restart enable

1) Single Phase products: Continuous operation (should be within rated input voltage, rated output power)

● Environment

Protection degree	IP 20, UL TYPE1 (Ambient Temperature 40 °C) ²⁾
Ambient temp	-10°C ~ 50°C
Storage temp	-20°C ~ 65°C
Humidity	Below 90% RH (no condensation)
Altitude/Vibration	Below 1,000m, 5.9m/sec ² (0.6G)
Atmospheric pressure	70~106 kPa
Location	Protected from corrosive gas, combustible gas, oil mist or dust

2) UL TYPE1 with top cover and conduit box installed.

8 Installation: Mechanical

8.1 Installing the Unit

Install AHUs on the floor. The floor mounted AHUs are factory fitted with supportive frame profiles.

The unit should be placed on a foundation slab, steel base frame concreted into the floor or an appropriate stiff steelwork. The foundation, steel base frame or steelwork have to be flat and leveled and they should be able to support the weight of the unit.

Height of the foundation slab or base frame must allow for assembly of the siphon which drains the condensate out of the draining tray.

Table 33 The W1 dimension for Fig. 19 and Fig. 20

AHU size	W1 [in]
AVS 8	26,56
AVS 12	37,22
AVS 16	42,81
AVS 20	45,37
AVS 30	52,11
AVS 40	57,66
AVS 55	64,74
AVS 65	73,84
AVS 85	81,48
AVS 100	77,54
AVS 130	93,60
AVS 170	97,22
AVS 230	116,91
AVS 300	136,59
AVS 380	141,00

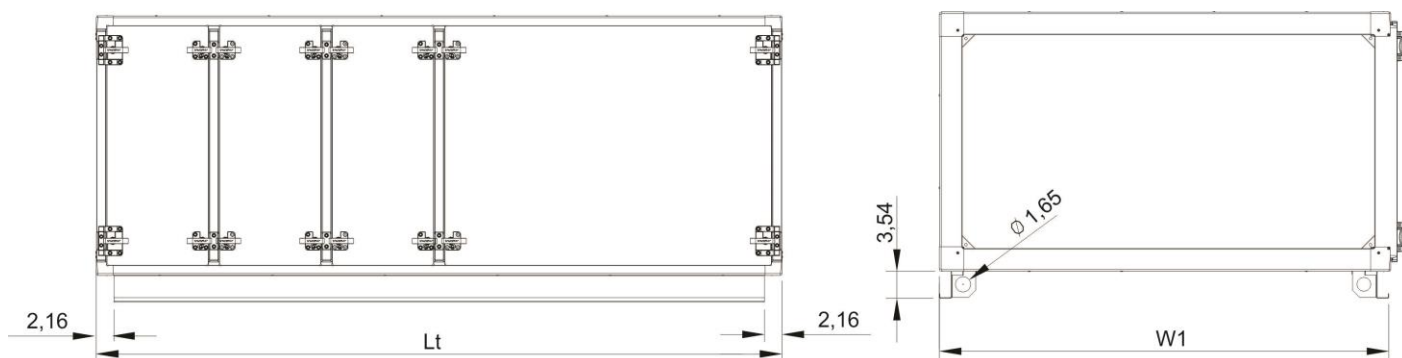

Fig. 19 The location of supportive frame profiles of AVS 8-40 AHUs, which length is less than 87 inches.

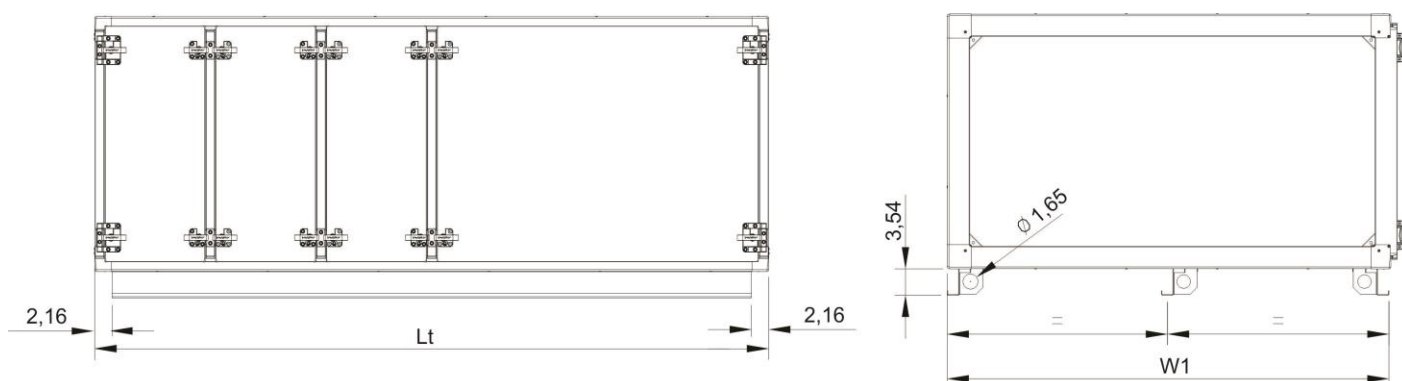

Fig. 20 The location of supportive frame profiles of AVS 55-85 AHUs, which length is less than 101 inches. W1 dimension is given in the table 26.

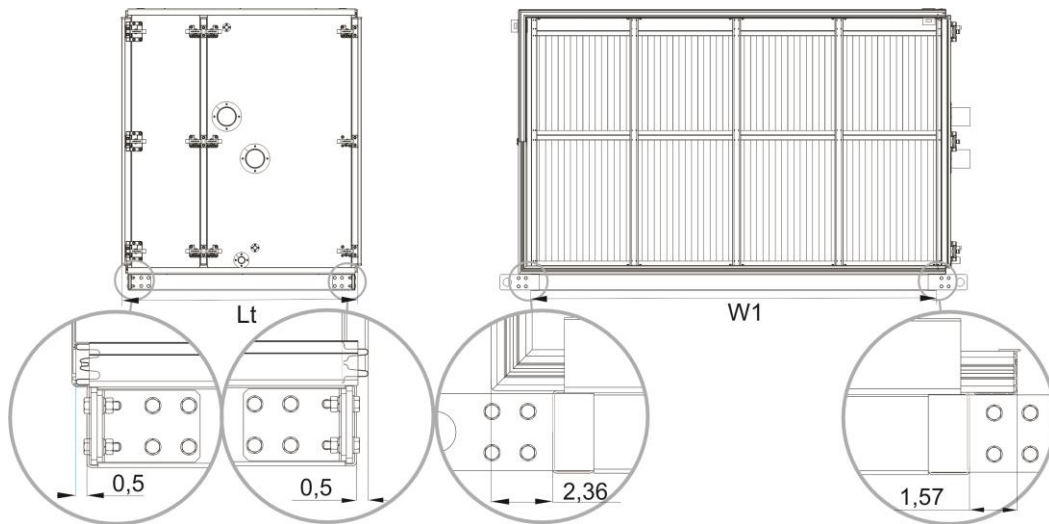

Fig. 21 The base frames of VTS 100-380 AHUs, which length is less than 86 inches. W1 dimension is given in the table 26.

When the unit is longer than 87 inches for AVS 40 and 101 inches for bigger sizes, the longitudinal profiles of base frame will be divided (Fig.42 and 43).

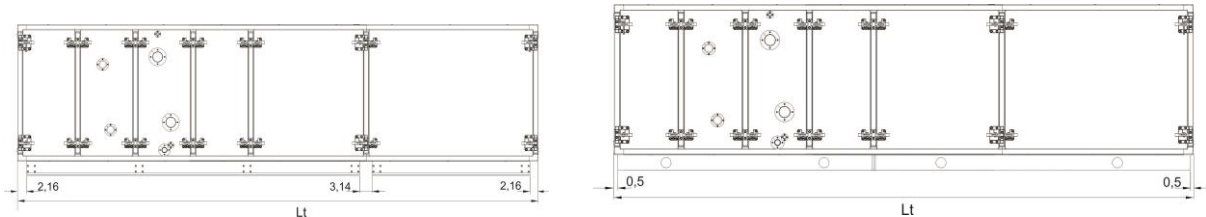

Fig. 22 The longitudinal frame profiles of AVS 8-85 AHUs, which length is more than 87 inches.

Fig. 23 The base frames of AVS 100-380 AHUs, which length is more than 86 inches.

For foundation holding of the AVS 8-85 AHUs should be drilled holes in the bottom part of the longitudinal profile (on the both ends) of base frame. To fix AHU base frame to foundation should be used bolts at least 3/8". For foundation holding of the AVS 100-380 AHUs should be fixed to the foundation with using the transport lugs.

Hanging the units

The horizontal AVS units can be installed suspended. Assembly of the AHU as a suspended device, in a line of ventilation ducts is to be carried out by the qualified personnel only, with the use of standard elements (not delivered/provided by VTS) used for suspending ventilation ducts (threaded rods and steel/aluminum bars or channels).

Allow:

- Adequate service clearances as recommended in this document.
- adequate service clearances for P-trap
- Unit has to be parallel (not inclined)
- Suspension device has to be installed on the beginning and end of each section, for units shipped by sections.

WARNING! Be sure that used elements are able to carry the weight equal to 150% of AHU weight that is provided on device nameplate.

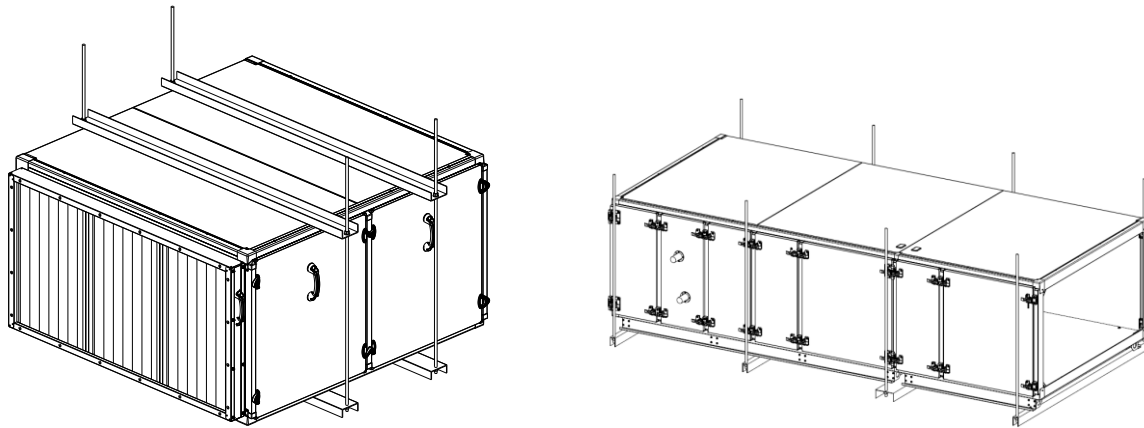

Fig. 24 Example of suspending the AHU with external rigging.

Curb, curb adaptor and curb cap mounted units

The horizontal AVS units can be mounted on a curb system. The curb system must include the curb, curb adaptor and curb cap. This system has to be designed to keep the rails of the unit out of the curb cap, while also preventing water penetration from the transverse posts/rails. The curb cap design must be fully welded & insulated with a pitch for positive run off, while the openings for the ductwork have to be sealed and only on the respective location of the Supply and Return air sections of the unit.

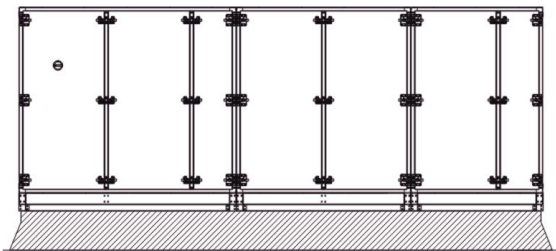

Fig 24-B Example of unit rails mounted on a curb system

The sections and lifting lugs have brackets going out of the rails; a better detail is shown on Figure 24-C:

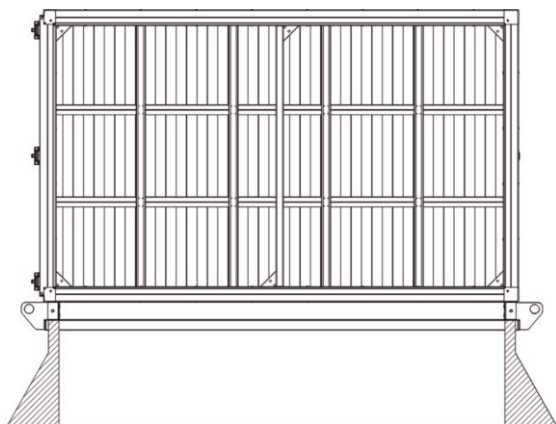

Fig 24-A Unit mounted on a curb system

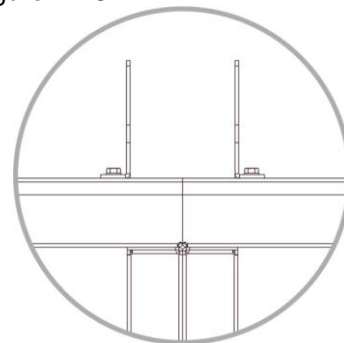

Fig 24-C Detail of the sections connected to the rails, where the lifting lugs are connected.

Figure 24-D shows example of the curb rails of the units consisting of two sections. Total length of the rail is the sum of the lengths of the all sections rails. If the length of the AHU section is higher then 59 inches in the middle of length is installed additional support rail bar.

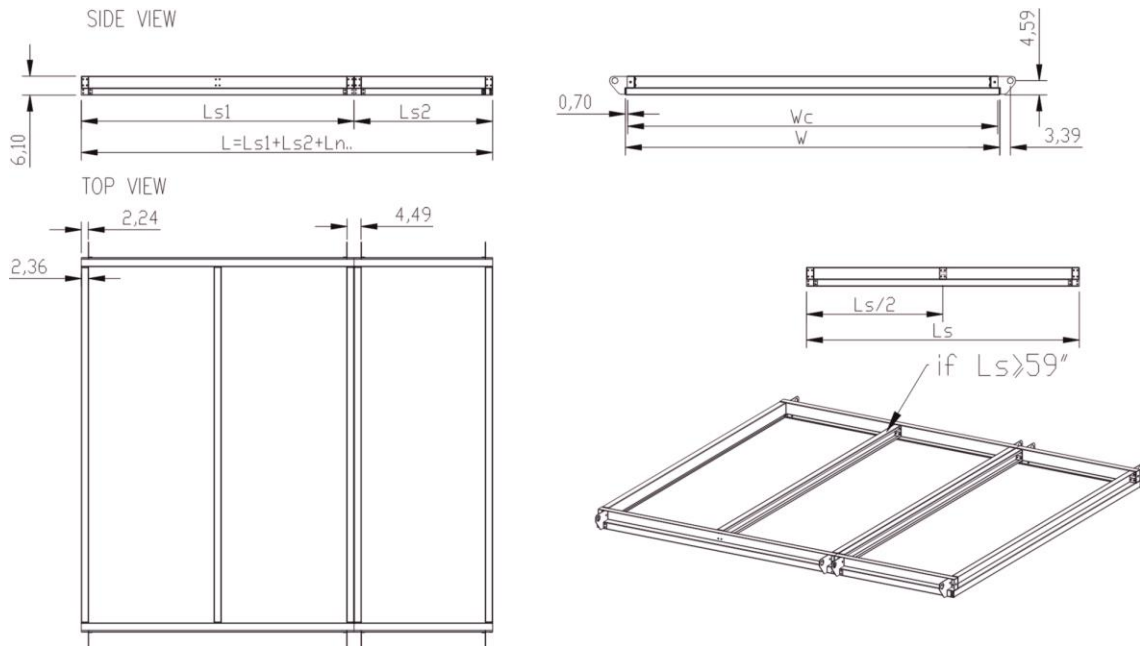

Fig 24-D Example of curb rails

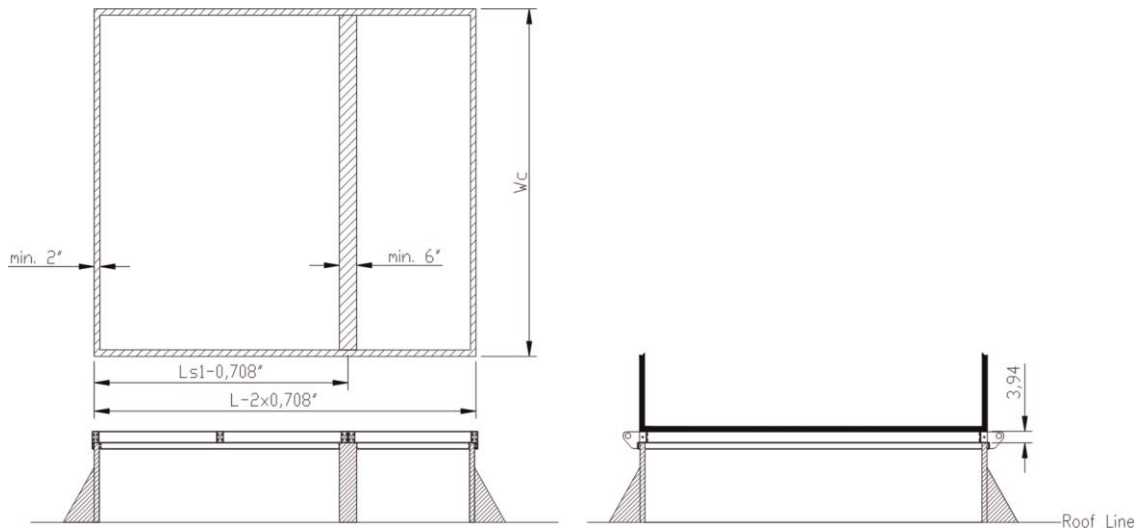

Fig 24-E Example of the unit curb support

	W	Wc	Ls [inch]
	[inch]	[inch]	
AVS008	26,22	24,80	30,69
AVS012	36,89	35,47	45,29
AVS016	42,48	41,06	59,90
AVS020	45,04	43,62	74,50
AVS030	51,77	50,35	89,10
AVS040	57,32	55,91	103,71
AVS055	64,41	62,99	
AVS065	73,50	72,09	
AVS085/100	81,14	79,72	
AVS130	97,20	95,79	
AVS170	100,83	99,41	
AVS230	120,59	119,17	
AVS300	140,28	138,86	
AVS380	144,69	143,27	

It is recommended that a closed cell gasket (not water absorbent) or other similar material be used to seal where the curb/casing is touching.

Allow:

- Adequate service clearances as recommended in this document.
- Adequate service clearances/height for P-trap
- Unit has to be parallel/level (not inclined).

⊙ **WARNING!** Be sure the curb system is able to carry the weight equal to 150% of AHU weight that is provided on device nameplate.

⊙ **WARNING!** Be sure that unit and curb system weight has been considered for

Unit Rails / I-Beams mounted unit

The horizontal AVS units can be mounted on unit rails system or I-beams. In the case of using I-beams, they will have to be 4" wide at a minimum. Each beam has to touch both perimeter rails, and exceed in length at least of 4" per side. The minimum number of cross sections beams will be determined by the number of sections of the unit plus one or every 30" of length of the unit, whichever number is greater.

Ductwork and ductwork connections have to be sealed and insulated to weather proof the installation.

Allow:

- Adequate service clearances as recommended in this document.
- Adequate service clearances/height for P-trap
- Unit has to be parallel (not inclined).
- Unit and unit rails system (or I-beams) have to be secured to the roof of the building or main civil structure.

- ✓ **WARNING!** *Be sure the unit rails are able to carry the weight equal to 150% of AHU weight that is provided on device nameplate.*
- ✓ **WARNING!** *Be sure that unit and unit rails weight has been considered for structural resistance of the Building, and approved by a Civil Engineer.*
- ✓ **WARNING!** *Be sure that each cross section I-beam is supporting each unit cross member to keep the sections of unit leveled.*

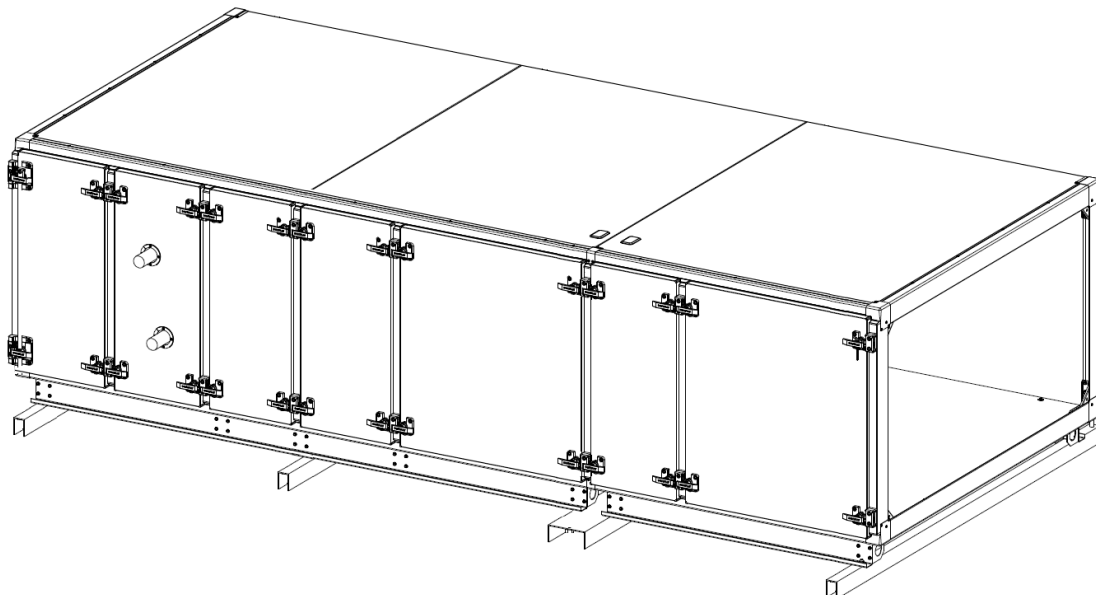

Fig 24-H Unit standing on top of Unit Rails or I-Beams

8.2 Condensate Drain Connections

✔ **NOTICE!** *It is the installer's responsibility to provide adequate condensate piping to prevent potential water damage to the equipment and/or building.*

Size the main drain lines and trap them the same size as the drain connection, which is 1 1/4".

The outlet condensate connections, led outside the AHU's casing are embedded in the drain plates underneath a glycol, cross-flow and rotary exchangers (the diameter of drain pan connection pipe is 1 1/4").

Drain traps, which are designed to drain out condensed water from the exchangers at the different pressure inside the AHU and environment, should be connected to the drain system.

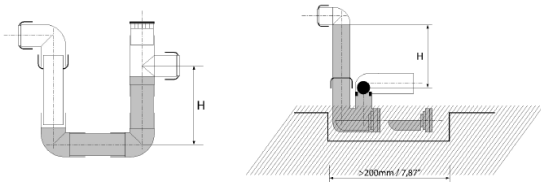

Fig. 25 Drain trap's type

Table 34 Drain trap's operational height

No.	Total fan's pressure [in w.g.]	Size H [in]
1.	<2,42	2,36
2.	2,42-4,03	3,94
3.	4,03-5,65	5,51
4.	5,65-7,26	7,09
5.	7,26-8,87	8,66

The "H" of the drain trap depends on the pressure difference between the AHU section, where condensate is drained from during operation and the ambient pressure. „H" dimension is provided in inches and must be higher than the pressure difference expressed in w.g.

All drain lines downstream of the trap must flow continuously downhill. If segments of the line are routed uphill, this can cause the drain line to become pressurized. A pressurized drain line may cause the trap to back up into the drain pan, causing overflow.

✔ **NOTICE!** *The manufacturer does not deliver drainage traps.*

For proper drainage of condensate from the unit, the P-trap on the drain pan connection pipe must be installed where the negative pressure occurs.

Plug or trap the auxiliary connection to prevent air from being drawn in and causing carryover fig. 45 and table 27.

✔ **NOTICE!** *Due to various pressure difference values which can be presented in various AHU sections during operation it is not allowable to connect several condensate outlets into one P-trap.*

It is possible to join together drain traps of various sections with one drain interceptor provided that the interceptor will be equipped with air-escape. Before starting the AHU, fill the siphon with water. In case of cold environment, insulate the water drain system and eventually apply suitable heating system.

✔ **NOTICE!** *Potential Coil-Freeze Condition!*
Make provisions to drain the coil when not in use to prevent coil freeze-up. Failure to follow this procedure could result in equipment/property damage.

8.3 Duct Connections

Before any service please make sure that any of AHU elements are not energized.

⚠ WARNING: Hazardous Voltage! Disconnect all electric power, including remote disconnects before servicing. Follow proper lockout/tag out procedures to ensure the power cannot be inadvertently energized. Failure to disconnect power before servicing could result in death or serious injury.

Install all air ducts according to the National Fire Protection Association standards for the "Installation of Air Conditioning and Ventilation Systems other than Residence Type (NFPA 90A) and Residence Type Warm Air Heating and Air Conditioning Systems (NFPA 90B).

The ducts connected to the AHU have to be suspended or underpinned with dedicated support elements. Conducting the ducts with the fittings should be done in a way to eliminate possible increase of noise level in the ventilation system.

Make duct connections to the unit with a flexible material such as heavy canvas to help minimize noise and vibration. Use three inches for the return duct and three inches for the discharge duct. Keep the material loose to absorb fan vibration.

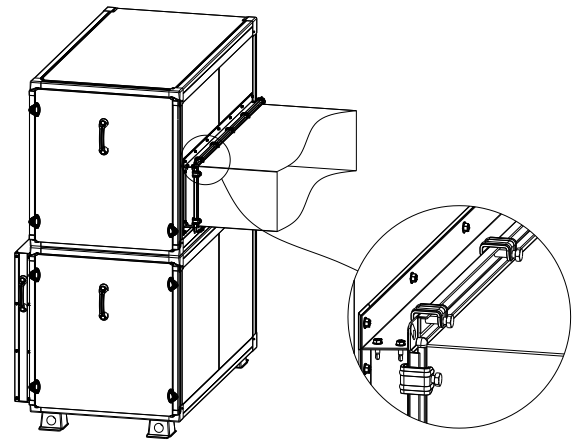

Fig. 26 Example of duct's connection

To achieve maximum acoustical performance, minimize the duct static pressure setpoint.

9 Installation: Piping

9.1 Hydronic Coil Connections

The water coils (hot water coils and chilled water coils) are fitted with threaded manifolds. Proper installation and piping is necessary to ensure satisfactory coil operation and prevent operational damage. Water inlet and outlet connections extend through the coil section inspection panel (see Figure 8). Follow standard piping practices when piping to the coil.

Connection of the coil exchangers should be carried out in such a way to prevent it from stresses which may result in mechanical damage or leakage. The pipeline weight and thermal stresses cannot be passed onto the exchanger's connections. Depending on local conditions please use the compensation at the supply and return of the pipeline system, in order to level the pipeline's linear expansion.

When connecting assembly of the supply system to the exchangers equipped with the threaded connections, counter the exchanger's connection with additional wrench (Fig.47).

The supply system should be planned in such a way that it doesn't get in the way of any maintenance work. Applied method of connecting the exchangers with the supply system should allow for an easy pipeline disassemble in order to remove the exchanger from the AHU, during service operations.

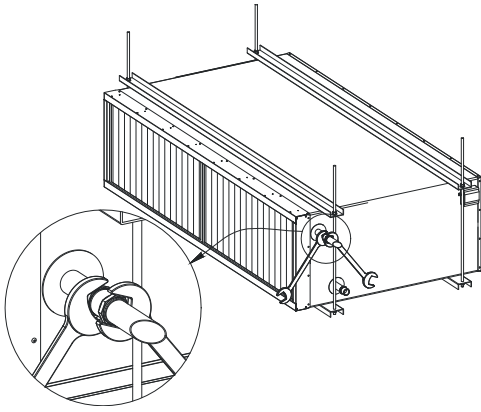

Fig. 27 Securing the threaded connections of the exchanger

The symbol of water coil (hot water and chilled water) consists of:

- AHU size - AVS **XX** and
- Number of rows WCL **Y**.

Table 35 Hydronic coil volume

Coils code	volume [dm ³]	Coils code	volume [dm ³]	Coils code	volume [dm ³]
AVS 8 WCL 1	0,75	AVS 55 WCL 3	16,74	AVS 130 WCL 6	57,59
AVS 8 WCL 2	1,47	AVS 55 WCL 4	21,16	AVS 130 WCL 8	76,78
AVS 8 WCL 3	2,11	AVS 55 WCL 6	29,87	AVS 170 WCL 1	19,44
AVS 8 WCL 4	2,74	AVS 55 WCL 8	43,5	AVS 170 WCL 2	25,69
AVS 8 WCL 6	4,01	AVS 65 WCL 1	6,65	AVS 170 WCL 3	42,22
AVS 8 WCL 8	5,27	AVS 65 WCL 2	10,37	AVS 170 WCL 4	51,38
AVS 12 WCL 1	1,29	AVS 65 WCL 3	19,62	AVS 170 WCL 6	77,07
AVS 12 WCL 2	1,77	AVS 65 WCL 4	20,74	AVS 170 WCL 8	102,76
AVS 12 WCL 3	2,66	AVS 65 WCL 6	31,11	AVS 230 WCL 1	25
AVS 12 WCL 4	3,54	AVS 65 WCL 8	41,48	AVS 230 WCL 2	34,71
AVS 12 WCL 6	5,31	AVS 85 WCL 1	8,83	AVS 230 WCL 3	69,91
AVS 12 WCL 8	7,08	AVS 85 WCL 2	12,87	AVS 230 WCL 4	87,09
AVS 20 WCL 1	2,18	AVS 85 WCL 3	23,8	AVS 230 WCL 6	104,13
AVS 20 WCL 2	3,25	AVS 85 WCL 4	25,74	AVS 230 WCL 8	138,84
AVS 20 WCL 3	4,87	AVS 85 WCL 6	38,61	AVS 300 WCL 1	38,12
AVS 20 WCL 4	6,49	AVS 85 WCL 8	51,47	AVS 300 WCL 2	42,65
AVS 20 WCL 6	9,74	AVS 100 WCL 1	12,97	AVS 300 WCL 3	71,92
AVS 20 WCL 8	12,98	AVS 100 WCL 2	15,62	AVS 300 WCL 4	85,3
AVS 40 WCL 1	4,8	AVS 100 WCL 3	35,64	AVS 300 WCL 6	127,95
AVS 40 WCL 2	8,2	AVS 100 WCL 4	31,24	AVS 300 WCL 8	170,6
AVS 40 WCL 3	11,54	AVS 100 WCL 6	46,86	AVS 380 WCL 1	51,06
AVS 40 WCL 4	14,92	AVS 100 WCL 8	62,47	AVS 380 WCL 2	56,79
AVS 40 WCL 6	23,37	AVS 130 WCL 1	14,73	AVS 380 WCL 3	95,38
AVS 40 WCL 8	30,12	AVS 130 WCL 2	19,2	AVS 380 WCL 4	113,58
AVS 55 WCL 1	6,01	AVS 130 WCL 3	41,15	AVS 380 WCL 6	170,37
AVS 55 WCL 2	10,41	AVS 130 WCL 4	38,39	AVS 380 WCL 8	227,16

⚠ CAUTION! *The maximum operation pressure is 300 PSI (20.7 bar). Testing pressure 493 PSI (34 bar). The maximum temperature is 200°F.*

Supply and return exchanger connections should be connected so as the exchanger operates in a counter flow way. A parallel flow of air and medium could result in lower mean temperature difference, thus in the lower exchanger's performance.

✔ NOTICE: *Potential Coil-Freeze Condition! Secure the coil against freezing-up! Failure to follow this procedure could result in equipment/property damage.*

Some examples of connecting of supply and return pipelines for various AHU versions are shown in the picture below.

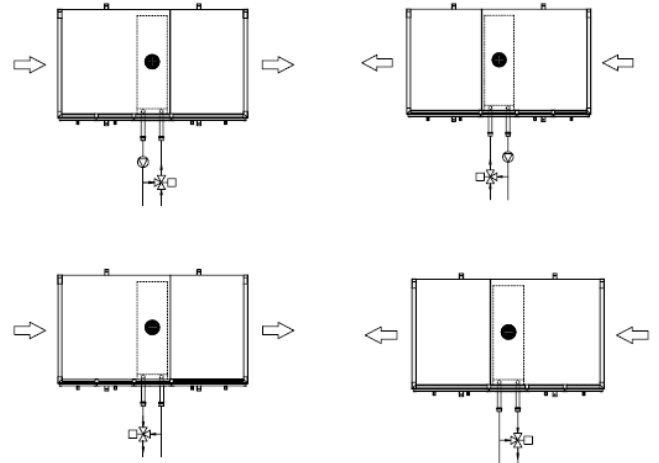

Fig. 28 Examples of feeding water exchangers (top view)

9.2 Steam Piping

Proper installation, piping and trapping is necessary to insure satisfactory and trouble-free operation of a heating coil.

The water coils are fitted with threaded manifolds.

✔ NOTICE: *Condensate must flow freely from the coil at all times to prevent coil damage from water hammer, unequal thermal stresses, freeze-up and/or corrosion. In all steam coil installations, the condensate return connections must be at the low point of the coil. Failure to follow these instructions could result in equipment damage.*

Please remember:

- To support all piping independently of coils.
- To provide swing joints or flexible fittings in all piping connections adjacent to heating coils to absorb expansion and contraction strains.
- Install coils so air passes through fins in proper direction (stenciled on top of coil channel).

⚠ CAUTION!
*Max operating temperature: 400 °F
 Max operating pressure: 72 PSI (5 bar)
 Testing pressure: 290 PSI (20 bar)*

1. Install 1/2-inch 15-degree swing check vacuum breaker in unused condensate return tapping as close as possible to coil. Vent vacuum breaker line to atmosphere or connect into return main at discharge side of steam trap. Vacuum relief is particularly important when coil is controlled by modulating steam supply or two-position (on-off) automatic steam supply valve.
2. Proper steam trap selection and installation is necessary for satisfactory coil performance and service life.
 - a. Select trap based on maximum possible condensate rate and recommended load factors.
 - b. Locate steam trap discharge at least 12 inches below condensate return tapping. This provides sufficient hydrostatic head pressure to overcome trap losses and assure complete condensate removal.

- c. Float and thermostatic traps are preferred because of gravity drain and continuous discharge operation.
 - d. Use float and thermostatic traps with atmospheric pressure gravity condensate return with automatic controls or where possibility of low pressure supply steam exists.
 - e. Bucket traps should only be used when supply steam is unmodulated and 25 psig or higher.
 - f. When installed with series airflow, size traps for each coil using capacity of first coil in airflow direction.
 - g. Always trap each coil separately to prevent condensate holdup in one or more coils.
 - h. Always install strainers as close as possible to inlet side of trap.
3. Use V-port modulating valves to obtain gradual modulating action or slow opening 2-position valves to prevent steam hammer.
 4. Use normally-open non-modulating control valves if coils are exposed to freezing air.
 5. Control each coil bank separately when installing coils for series airflow with automatic steam control valves.
 6. Do not modulate steam or use on-off supply control on systems with overhead or pressurized returns unless condensate is drained by gravity to receiver (vented to atmosphere) and returned to main by condensate pump.
 7. At startup with dampers, slowly turn steam on full for at least 10 minutes before opening fresh air intake.
 8. Pitch all supply and return steam piping down a minimum of one inch per 10 feet in direction of flow.
 9. Do not drain steam mains or take-offs through coils. Drain mains ahead of coils through steam trap to return line.
 10. Do not bush or reduce coil return tapping size. Run return pipe full size of steam trap connection except for short nipple screwed directly into coil condensate connection.
 11. Overhead returns require 1 psig pressure at steam trap discharge for each 2-foot elevation to assure continuous condensate removal.

9.3 Refrigerant Coil Piping

The DX cooling coils are intended to be connected to a condensing unit. Some condensing units can have one, two or more independent refrigeration circuits. Therefore the DX coolers must be matched accordingly taking into consideration aspects such as: number of circuits, cooling capacity, temperature of evaporation (pressure of evaporation), sizes of coil headers, and capacity of medium.

The DX coolers can cooperate with various refrigerants, selection of specific refrigerant and its operational parameters are presented in the AHU nameplate.

Units shall not have refrigerant temperatures and pressures exceeding that listed on the unit nameplate. Follow accepted refrigeration

piping practices and safety precautions for typical refrigerant coil piping and components.

The DX coolers are delivered without refrigerant. They are filled up with nitrogen under 1 bar pressure. Follow accepted refrigeration piping practices and safety precautions for typical refrigerant coil piping and components. Specific recommendations are provided with the compressor unit, including instructions for pressure-testing, evacuation, and system charging. Conduct a leak test of the entire refrigerant system after all piping is complete. Charge the unit according to approximate weight requirements, operating pressures, and superheat/ sub-cooling measurements. Adjust the thermal expansion valve setting, if necessary, for proper superheat.

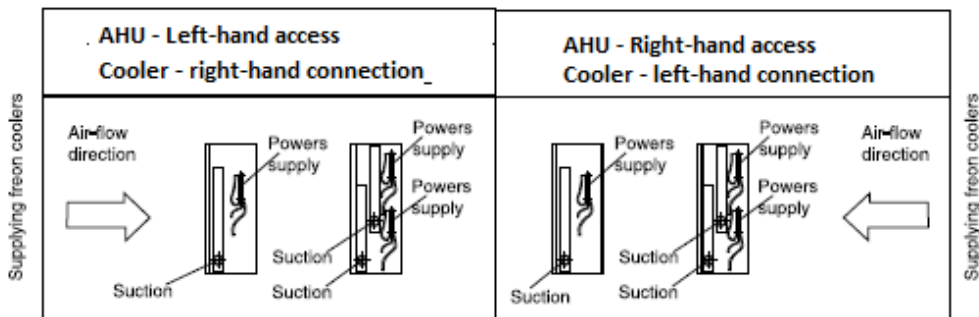

Fig. 29 Feeding DX coolers

⚠ WARNING: Hazard of Explosion and Deadly Gases!

- **Never solder, braze or weld on refrigerant lines or any unit components that are above atmospheric pressure or where refrigerant may be present.**
- **Every time remove refrigerant by following the guidelines established by the EPA Federal Clean Air Act or other state or local codes as appropriate.**
- **After refrigerant removal, use dry nitrogen to bring system back to atmospheric pressure before opening system for repairs.**
- **Mixtures of refrigerants and air under pressure may become combustible in the presence of an ignition source leading to an explosion. Excessive heat from soldering, brazing or welding with refrigerant vapors present can form highly toxic gases and extremely corrosive acids.**
- **Failure to follow all proper safe refrigerant handling practices could result in death or serious injury.**

✔ **NOTICE:** *The DX coils have sweat connections. When brazing or welding piping: avoid exposing piping components to high heat when making sweat connections and protect the closest valve to the connection with a wet rag.*

✔ **NOTICE:** *Do not release refrigerant to the atmosphere! If adding or removing refrigerant is required, the service technician must comply with all federal, state, and local laws.*

⚠ **CAUTION!** The maximum operation pressure is 304 PSI (21 bar). Testing pressure is 493 PSI (34 bar).

✔ **NOTICE:** *Secure the coil against frost on the coil.*

✔ **NOTICE:** *To ensure satisfactory operation of DX coolers the coolers should be connected to the refrigerant system in accordance with all relevant regulations, rules and the best practice for that area.*

Liquid Line

Line Sizing. Properly sizing the liquid line is critical to a successful application. If provided, use the liquid line size recommended by the manufacturer of the compressor unit. The selected tube diameter must be as small as possible, while still providing at least 5°F [2.7°C] of sub-cooling at the expansion valve throughout the operating envelope.

Routing. Install the liquid line with a slight slope in the direction of flow so that it can be routed with the suction line. Minimize tube bends and reducers because these items tend to increase pressure drop and reduce sub-cooling at the expansion valve. Insulation. The liquid line is generally warmer than the surrounding air, so it does not require insulation.

Suction Line

Line sizing. Properly sizing the suction line is critical for ensuring that the oil returns to the compressor throughout the system operating envelope. If provided, use the suction line size(s) recommended by the manufacturer of the compressor unit. The selected tube diameter(s) must maintain adequate refrigerant velocities at all operating conditions.

slightly - 1 inch per 10 feet of run [1 cm per 3 m]—toward the evaporator. Avoid putting refrigerant lines underground. Refrigerant condensation, installation debris inside the line, service access, and abrasion/corrosion can quickly impair system reliability.

Routing. To prevent residual or condensed refrigerant from “free-flowing” toward the compressor, install the suction line so it slopes

Insulation. After operating the system and testing all fittings and joints to verify the system is leak-free, insulate the suction lines

10 Pre-Start

Pre-Start Checklist

Complete this checklist after installing the unit to verify all recommended installation procedures are complete before unit startup. This does not replace the detailed instructions in the appropriate sections of this manual. Disconnect electrical power before performing this checklist. Always read the entire section carefully to become familiar with the procedures

Receiving

- Inspect unit and components for shipping damage. File damage claims immediately with the delivering carrier.
- Check unit for missing material. Look for ship-with drives, isolators, filters, and sensors that are packaged separately and placed inside the main control panel, fan section, or compressor section (see “Receiving and Handling,”).
- Check nameplate unit data so that it matches the sales order requirements.

Unit Location

- Remove crating from the unit. Do not remove the shipping skid until the unit is set in its final position.
- Ensure the unit location is adequate for unit dimensions, ductwork, piping, and electrical connections.
- Ensure access and maintenance clearances around the unit are adequate. Allow space at the end of the unit for shaft removal and servicing (see “Service Access,”).

Unit Mounting

- Place unit in its final location.
- Remove shipping skid bolts and skid.
- If using isolators, properly mount unit according to the isolator placement sheet.

Component Overview

- Ensure the fan rotates freely in the correct direction.
- Verify that a clean air filter is in place.

- If using return ductwork to the unit, secure it with three inches of flexible duct connector.
- Use a 3” flexible duct connection on discharge ductwork.
- Ensure trunk ductwork is complete and secure to prevent leaks.
- Verify that all ductwork conforms to NFPA 90A or 90B and all applicable local codes.

Unit Piping

- Verify the condensate drain piping is complete for the unit drain pan. Install and tighten the condensate “P” trap drain plug.
- Make return and supply water connections to the unit and/or piping package.
- Ensure the drain pan and condensate line is not obstructed. Remove any foreign matter that may have fallen into the drain pan during installation.
- Verify that piping does not leak. Make sure drain lines are open while performing the leak test.
- Treat water to prevent algae, slime, and corrosion.
- Connect refrigerant piping lines.
- Connect steam supply line, condensate return line, and vacuum breaker line to coil in accordance with steam piping recommendations

Electrical

- Check all electrical connections for tightness.
- Verify motor voltage and amps on all phases with the unit nameplate ratings to ensure unit operates correctly.

Unit Panels

- Ensure all unit access panels are in place and that all screws, nuts, and bolts are tightened to their proper torques.

⊙ **NOTICE!** During the unit break-in period, bearing temperature may be 150°F–160°F. during normal operation bearing temperature should range be 90°F–100°F.

11 Maintenance

11.1 Maintenance Procedures.

Perform the following maintenance procedures to ensure proper unit operation.

Air Filters

Always install filters with directional arrows pointing toward the fan. For units with high efficiency filters (MERV 8 or MERV 13), the filters need to be replaced with equivalent MERV-rated filters to maintain unit performance.

Fan Bearings

Fan bearings are permanently sealed and lubricated and do not require additional lubrication.

Fan Motors

Inspect fan motors periodically for excessive vibration or temperature. Operating conditions will vary the frequency of inspection.

 **WARNING! Hazardous Voltage!**
Disconnect all electric power, including remote disconnects before servicing. Follow proper lockout procedures to ensure the power cannot be inadvertently energized. Failure to disconnect power before servicing could result in death or serious injury.

Fans

Fans are designed for transferring dust-free or light-dusted air. They are not designed for aggressive gases, steams or heavy-dusted air. Operating the fan in not suitable environment can lead to damage of bearings, corrosion, unbalanced rotor or vibrations.

The fan and motor in the unit are designed for particular requirements and operation characteristics. Fan rotation speed is adapted so as the air stream and complete fan stress concentration were appropriate for a given ventilation system. Smaller stream of forced air results in disturbances in correct operation and

leads to loss of balance of the entire ventilation system. It can be caused by:

- dust settlings on the fan's rotor blades,
- Incorrect direction of fan's rotations. If the centrifugal fan rotates in incorrect direction, the air flow is carried out with significantly deteriorated output.

In case of fan maintenance activities check if:

- the rotor rotates freely,
- the rotor is well balanced,
- the rotor is firmly mounted on pivot,
- did not change a location against the inlet funnel,
- vibro-isolators are firmly installed and they are not damaged,
- flexible connection (if any) is not damaged,
- All screws fastening construction elements of the fan unit are tight.

Electric heater

Electric heater's battery consists of bare heating coils. During AHU operation, when the heater does not work, dust may settle onto the heating coils. Once the heater is turned on again, strong contamination may cause smell of burning dust or even preliminary fire danger may appear.

Check regularly (every year) and especially before starting a heating period, any electric connections, condition of heating elements and their contamination level. Any possible contamination should be removed with a vacuum cleaner with soft suction nozzle or with compressed air.

Also check operation of overheating protection in case of lack of air-flow. Air speed should not be lower than 295 FPM.

 **WARNING!** Wet cleaning of electric heater is forbidden!

11.2 Coil Maintenance

☑ NOTICE!

Potential Unit Damage from Coil Cleaners!
Do not use acidic chemical coil cleaners. Also, do not use alkaline chemical coil cleaners with a pH value greater than 8.5 (after mixing) without using an aluminum corrosion inhibitor in the cleaning solution. Using these types of cleaners could result in equipment damage.

Keep coils clean to maintain maximum performance. For operation at its highest efficiency, clean the coil often during periods of high demand or when dirty conditions prevail. Clean the coil a minimum of once per year to prevent dirt buildup in the coil fins, where it may not be visible. Remove large debris from the coils and straighten fins before cleaning. Remove filters before cleaning. Rinse coils thoroughly after cleaning. Clean the coil fins using one of these methods:

- with a vacuum cleaner with soft suction nozzle from the air inlet side
- by blowing through with compressed air in a direction opposite to normal air flow direction, directing air stream in parallel to the lamellas
- washing with hot water or steam with detergent which do not cause aluminum or copper corrosion
- commercially available chemical coil cleaner

If in the units are two coils one near to another, the first in the air direction, should be cleaned with the vacuum cleaner and the second by blowing with compressed air in direction opposite to the normal air flow direction.

Inspecting and Cleaning Coils

Coils become externally fouled as a result of normal operation. Dirt on the coil surface reduces its ability to transfer heat and can cause comfort problems, increased airflow resistance and thus increased operating energy costs. If the coil surface dirt becomes wet, which commonly occurs with cooling coils, microbial growth (mold) may result, causing unpleasant odors and serious health-related indoor air quality problems.

Inspect coils at least every six months or more frequently as dictated by operating experience. Cleaning frequently is dependent upon system operating hours, filter maintenance, and efficiency and dirt load. Follow is the suggested method below:

Hot Water and Cooling Coil Cleaning Procedure

⚠ WARNING! Hazardous Chemicals!

Coil cleaning agents can be either acidic or highly alkaline. Handle chemical carefully. Proper handling should include goggles or face shield, chemical resistant gloves, boots, apron or suit as required. For personal safety refer to the cleaning agent manufacturer's Materials Safety Data Sheet and follow all recommended safe handling practices. Failure to follow all safety instructions could result in death or serious injury.

1. Don the appropriate personal protective equipment (PPE).
2. Gain access to the coil section.
3. Use a soft brush to remove loose debris from both sides of the coil.
4. Use a steam cleaning machine, starting from the top of the coil and working downward. Clean the leaving air side of the coil first, then the entering air side. Use a block-off to prevent steam from blowing through the coil and into a dry section of the unit.
5. Repeat Step 4 as necessary. Confirm that the drain line is open following completion of the cleaning process.
6. Allow the unit to dry thoroughly before putting the system back into service.
7. Straighten any coil fins that may be damaged with a fin rake.
8. Replace all panels and parts and restore electrical power to the unit.
9. Ensure that contaminated material does not contact other areas of the unit or building. Properly dispose of all contaminated materials and cleaning solutions.

Winterizing the Coil

Make provisions to drain coils that are not in use, especially when subjected to freezing temperatures. To drain the coil, first blow out the coil with compressed air. Next, fill and drain the tubes with full-strength ethylene glycol several times. Then drain the coil as completely as possible.

⚠ NOTICE! Potential Coil-Freeze Condition!

Make provisions to drain the coil when not in use to prevent coil freeze-up. Failure to follow this procedure could result in equipment damage.

11.3 Periodic Maintenance Checklists

The following check list provides the recommended maintenance schedule to keep the unit running efficiently.

⚠ WARNING! Rotating Parts!
Secure drive to ensure motor cannot freewheel. Failure to follow this procedure could result in death, personal injury or equipment damage.

⚠ WARNING! Hazardous Voltage!
Disconnect all electric power, including remote disconnects before servicing. Follow proper lockout/ tag out procedures to ensure the power cannot be inadvertently energized. Failure to disconnect power before servicing could result in death or serious injury.

Monthly Checklist

1. Inspect unit air filters. Clean or replace if airflow is blocked or if filters are dirty.
2. Inspect the coils for dirt build-up. Clean fins if airflow is clogged.
3. Measure the current absorbed by the unit.

Semi-Annual Maintenance

1. With power disconnected, manually rotate the fan wheel to check for obstructions in the fan diaphragm or interference with fan blades. Remove any obstructions and debris.
2. Inspect the coils, cross-flow plate exchanger, heat wheel for dirt build-up. Clean fins if airflow is clogged.

Annual Maintenance

Check and tighten all set screws, bolts, locking collars and sheaves.

1. Inspect, clean, and tighten all electrical connections and wiring.
2. Visually inspect the entire unit casing for chips or corrosion. Remove rust or corrosion and repaint surfaces.
3. Clean fan wheels. Remove any rust from the fan shaft with an emery cloth and recoat with L.P.S. 3 or equivalent.
4. Inspect the drain pan for sludge or other foreign material. Clear the drain openings and drain line to ensure adequate flow.
5. Rotate the fan wheel and check for obstructions in the fan diaphragm. The wheel should not rub on the fan diaphragm.
6. Examine flex connector for cracks or leaks.
7. Repair or replace any damaged duct material.